



1997-1998 FREEZERS

(Including Private Label Brands)

PRODUCT INFORMATION AND TECHNICAL GUIDE

 **FRIGIDAIRE**

TAPPAN

 White-Westhouse

Gibson

TABLE OF CONTENTS

SAFE SERVICING PRACTICES	2
---------------------------------------	----------

ELECTRICAL SPECIFICATIONS

Frigidaire	3 - 4
Gibson	4 - 5
Universal/Multiflex	5 - 8
Private Labels:	
Broich	8 - 9
Edina Tech	9
Tappan	9
Venex Inc.	9

SYSTEM SPECIFICATIONS

Frigidaire	10 - 11
Gibson	11 - 12
Universal/Multiflex	12 - 15
Private Labels:	
Broich	15 - 16
Edina Tech	16
Tappan	16
Venex Inc.	16

SCHEMATICS INDEX LIST

Frigidaire	17 - 18
Gibson	18 - 19
Universal/Multiflex	19 - 22
Private Labels:	
Broich	22
Edina Tech	23
Tappan	23
Venex Inc.	23

SCHEMATICS

Electrical Circuits	24 - 27
Relay / Overload Schematics	28
System Schematics	29 - 30

TROUBLESHOOTING	31 - 34
------------------------------	----------------

NOTES	35
--------------------	-----------

This service manual is intended for use by persons having electrical and mechanical training and a level of knowledge of these subjects generally considered acceptable in the appliance repair trade. Frigidaire Home Products cannot be responsible, nor assume any liability, for injury or damage of any kind arising from the use of this manual.

SAFE SERVICING PRACTICES - ALL APPLIANCES

To avoid the possibility of personal injury and/or property damage, it is important that safe servicing practices be observed. The following are examples, but without limitation, of such practices:

1. Do not attempt a product repair if you have any doubts as to your ability to complete it in a safe and satisfactory manner.
2. Before servicing or moving an appliance:
 - remove power cord from electric outlet, trip circuit breaker to OFF, or remove fuse
 - turn off gas supply
 - turn off water supply
3. Never interfere with the proper operation of any safety device.
4. USE ONLY REPLACEMENT PARTS CATALOGED FOR THIS APPLIANCE. SUBSTITUTIONS MAY DEFEAT COMPLIANCE WITH SAFETY STANDARDS SET FOR HOME APPLIANCES.
5. GROUNDING: The standard color coding for safety ground wires is GREEN, or GREEN with YELLOW STRIPES. Ground leads are not to be used as current carrying conductors. IT IS EXTREMELY IMPORTANT THAT THE SERVICE TECHNICIAN REESTABLISH ALL SAFETY GROUNDS PRIOR TO COMPLETION OF SERVICE. FAILURE TO DO SO WILL CREATE A POTENTIAL HAZARD.
6. Prior to returning the product to service, ensure that:
 - all electric connections are correct and secure
 - all electrical leads are properly dressed and secured away from sharp edges, high-temperature components, and moving parts
 - all uninsulated electrical terminals, connectors, heaters, etc. are adequately spaced away from all metal parts and panels
 - all safety grounds (both internal and external) are correctly and securely connected
 - all panels are properly and securely reassembled

FRIGIDAIRE ELECTRICAL SPECIFICATIONS

MODELS	Control Thermostat Calibration °F		Defrost Timer		Defrost Thermostat Calibration °F		Defrost Heater	
	Warm Position	Cold Position	Defrost Cycle (Min.)	Accum. Run Time (Hrs.)	Close	Open	Watts	Ohms
	Cut-In	Cut-Out						
FFC05M5CW2	6.3 ± 3	-24.5 ± 3	-	-	-	-	-	-
FFC05M5CW3	6.3 ± 3	-24.5 ± 3	-	-	-	-	-	-
FFC07M5CW2	6.3 ± 3	-24.5 ± 3	-	-	-	-	-	-
FFC07M5CW3	6.3 ± 3	-24.5 ± 3	-	-	-	-	-	-
FFC09M5CW2	6.3 ± 3	-24.5 ± 3	-	-	-	-	-	-
FFC13D9EW1	14.0 ± 3	-22.3 ± 3	-	-	-	-	-	-
FFC13D9EW2	14.0 ± 3	-22.3 ± 3	-	-	-	-	-	-
FFC13M6CW2	6.3 ± 3	-24.5 ± 3	-	-	-	-	-	-
FFC15D9CW2	14.0 ± 3	-22.3 ± 3	-	-	-	-	-	-
FFC15M6CW2	6.3 ± 3	-24.5 ± 3	-	-	-	-	-	-
FFC20D7GW0	6.3 ± 3	-24.5 ± 3	-	-	-	-	-	-
FFC20D7GW1	14.0 ± 3	-22.3 ± 3	-	-	-	-	-	-
FFC20M7CW1	14.0 ± 3	-22.3 ± 3	-	-	-	-	-	-
FFU09M5CW2	11.4 ± 3	-20.3 ± 3	-	-	-	-	-	-
FFU09M5GW0	11.4 ± 3	-20.3 ± 3	-	-	-	-	-	-
FFU12D9EW1	11.4 ± 3	-20.3 ± 3	-	-	-	-	-	-
FFU12D9EW2	11.4 ± 3	-20.3 ± 3	-	-	-	-	-	-
FFU12D9GW2	11.4 ± 3	-20.3 ± 3	-	-	-	-	-	-
FFU12M5CW2	11.4 ± 3	-20.3 ± 3	-	-	-	-	-	-
FFU12M5GW0	11.4 ± 3	-20.3 ± 3	-	-	-	-	-	-
FFU14F9FW0	6.2 ± 3	-21.2 ± 3	29.9 ± 3.6	12	30 ± 5	50 ± 5	550 ± 5%	24
FFU14F9FW1	6.2 ± 3	-21.2 ± 3	29.9 ± 3.6	12	30 ± 5	50 ± 5	550 ± 5%	24
FFU14F9GW0	6.2 ± 3	-21.2 ± 3	29.9 ± 3.6	12	30 ± 5	50 ± 5	550 ± 5%	24
FFU14F9GW1	6.2 ± 3	-21.2 ± 3	29.9 ± 3.6	12	30 ± 5	50 ± 5	550 ± 5%	24
FFU14M8CW2	11.4 ± 3	-20.3 ± 3	-	-	-	-	-	-

FRIGIDAIRE ELECTRICAL SPECIFICATIONS

MODELS	Control Thermostat Calibration °F		Defrost Timer		Defrost Thermostat Calibration °F		Defrost Heater	
	Warm Position	Cold Position	Defrost Cycle (Min.)	Accum. Run Time (Hrs.)	Close	Open	Watts	Ohms
	Cut-In	Cut-Out						
FFU14M8GW0	11.4 ± 3	-20.3 ± 3	-	-	-	-	-	-
FFU16F9FW0	6.2 ± 3	-21.2 ± 3	29.9 ± 3.6	12	30 ± 5	50 ± 5	550 ± 5%	24
FFU16F9FW1	4.0 ± 2	-24.0 ± 2	29.9 ± 3.6	12	30 ± 5	50 ± 5	550 ± 5%	24
FFU17D9GW0	8.5 ± 3	-21.0 ± 3	-	-	-	-	-	-
FFU17F9GW0	4.0 ± 2	-24.0 ± 2	29.9 ± 3.6	12	30 ± 5	50 ± 5	550 ± 5%	24
FFU17F9GW1	4.0 ± 2	-24.0 ± 2	29.9 ± 3.6	12	30 ± 5	50 ± 5	550 ± 5%	24
FFU17M8GW0	8.5 ± 3	-21.0 ± 3	-	-	-	-	-	-
FFU20F9FW0	6.2 ± 3	-21.2 ± 3	29.9 ± 3.6	12	30 ± 5	50 ± 5	550 ± 5%	24
FFU20F9FW1	4.0 ± 2	-24.0 ± 2	29.9 ± 3.6	12	30 ± 5	50 ± 5	550 ± 5%	24
FFU20F9GW0	4.0 ± 2	-24.0 ± 2	29.9 ± 3.6	12	30 ± 5	50 ± 5	550 ± 5%	24
FFU20F9GW1	4.0 ± 2	-24.0 ± 2	29.9 ± 3.6	12	30 ± 5	50 ± 5	550 ± 5%	24
FFU20G9FW0	4.0 ± 2	-24.0 ± 2	29.9 ± 3.6	12	30 ± 5	50 ± 5	550 ± 5%	24
FFU20G9FW1	4.0 ± 2	-24.0 ± 2	29.9 ± 3.6	12	30 ± 5	50 ± 5	550 ± 5%	24
FFU20G9GW0	4.0 ± 2	-24.0 ± 2	29.9 ± 3.6	12	30 ± 5	50 ± 5	550 ± 5%	24
FFU20G9GW1	4.0 ± 2	-24.0 ± 2	29.9 ± 3.6	12	30 ± 5	50 ± 5	550 ± 5%	24
FFU21M8GW0	8.5 ± 3	-21.0 ± 3	-	-	-	-	-	-

GIBSON ELECTRICAL SPECIFICATIONS

GFC05M3EW1	6.3 ± 3	-24.5 ± 3	-	-	-	-	-	-
GFC05M3EW2	6.3 ± 3	-24.5 ± 3	-	-	-	-	-	-
GFC07M3EW1	6.3 ± 3	-24.5 ± 3	-	-	-	-	-	-
GFC07M3EW2	6.3 ± 3	-24.5 ± 3	-	-	-	-	-	-
GFC09M3EW1	6.3 ± 3	-24.5 ± 3	-	-	-	-	-	-
GFC09M3EW2	6.3 ± 3	-24.5 ± 3	-	-	-	-	-	-
GFC15D4GW0	14.0 ± 3	-22.3 ± 3	-	-	-	-	-	-
GFC15D4GW1	14.0 ± 3	-22.3 ± 3	-	-	-	-	-	-

GIBSON ELECTRICAL SPECIFICATIONS

MODELS	Control Thermostat Calibration °F		Defrost Timer		Defrost Thermostat Calibration °F		Defrost Heater	
	Warm Position	Cold Position	Defrost Cycle (Min.)	Accum. Run Time (Hrs.)	Close	Open	Watts	Ohms
	Cut-In	Cut-Out						
GFC15M4AW4	14.0 ± 3	-22.3 ± 3	-	-	-	-	-	-
GFC20M4GW0	14.0 ± 3	-22.3 ± 3	-	-	-	-	-	-
GFC20M4GW1	14.0 ± 3	-22.3 ± 3	-	-	-	-	-	-
GFU12M2AW6	11.4 ± 3	-20.3 ± 3	-	-	-	-	-	-
GFU12M2GW0	11.1 ± 3	-27.7 ± 3	-	-	-	-	-	-
GFU14M3AW7	11.4 ± 3	-20.3 ± 3	-	-	-	-	-	-
GFU14M3GW0	11.1 ± 3	-27.7 ± 3	-	-	-	-	-	-
GFU16F7FW0	4.0 ± 2	-24.0 ± 2	29.9 ± 3.6	12	30 ± 5	50 ± 5	550 ± 5%	24
GFU16F7FW1	4.0 ± 2	-24.0 ± 2	29.9 ± 3.6	12	30 ± 5	50 ± 5	550 ± 5%	24
GFU17F7FW0	4.0 ± 2	-24.0 ± 2	29.9 ± 3.6	12	30 ± 5	50 ± 5	550 ± 5%	24
GFU17F7FW1	4.0 ± 2	-24.0 ± 2	29.9 ± 3.6	12	30 ± 5	50 ± 5	550 ± 5%	24
GFU17F7GW1	4.0 ± 2	-24.0 ± 2	-	-	-	-	-	-
GFU17M4GW0	8.8 ± 3	-21.0 ± 3	-	-	-	-	-	-
GFU20F7FW0	4.0 ± 2	-24.0 ± 2	29.9 ± 3.6	12	30 ± 5	50 ± 5	550 ± 5%	24
GFU20F7FW1	4.0 ± 2	-24.0 ± 2	29.9 ± 3.6	12	30 ± 5	50 ± 5	550 ± 5%	24
GFU20F7GW0	4.0 ± 2	-24.0 ± 2	29.9 ± 3.6	12	30 ± 5	50 ± 5	550 ± 5%	24
GFU20F7GW1	4.0 ± 2	-24.0 ± 2	29.9 ± 3.6	12	30 ± 5	50 ± 5	550 ± 5%	24
GFU21D9FW0	8.8 ± 3	-21.0 ± 3	-	-	-	-	-	-
GFU21M4GW0	8.8 ± 3	-21.0 ± 3	29.9 ± 3.6	12	30 ± 5	50 ± 5	550 ± 5%	24

UNIVERSAL / MULTIFLEX ELECTRICAL SPECIFICATIONS

MFC05M0BW3	6.3 ± 3	-24.5 ± 3	-	-	-	-	-	-
MFC05M0BW4	6.3 ± 3	-24.5 ± 3	-	-	-	-	-	-
MFC05M1FW0	6.3 ± 3	-24.5 ± 3	-	-	-	-	-	-
MFC05M1FW1	6.3 ± 3	-24.5 ± 3	-	-	-	-	-	-
MFC05M3BW3	6.3 ± 3	-24.5 ± 3	-	-	-	-	-	-
MFC05M3BW4	6.3 ± 3	-24.5 ± 3	-	-	-	-	-	-

UNIVERSAL / MULTIFLEX ELECTRICAL SPECIFICATIONS

MODELS	Control Thermostat Calibration °F		Defrost Timer		Defrost Thermostat Calibration °F		Defrost Heater	
	Warm Position	Cold Position	Defrost Cycle (Min.)	Accum. Run Time (Hrs.)	Close	Open	Watts	Ohms
	Cut-In	Cut-Out						
MFC07M1BW3	6.3 ± 3	-24.5 ± 3	-	-	-	-	-	-
MFC07M1BW4	6.3 ± 3	-24.5 ± 3	-	-	-	-	-	-
MFC07M3BW3	6.3 ± 3	-24.5 ± 3	-	-	-	-	-	-
MFC07M3BW4	6.3 ± 3	-24.5 ± 3	-	-	-	-	-	-
MFC07M3FW0	6.3 ± 3	-24.5 ± 3	-	-	-	-	-	-
MFC07M3FW1	6.3 ± 3	-24.5 ± 3	-	-	-	-	-	-
MFC09M1BW3	6.3 ± 3	-24.5 ± 3	-	-	-	-	-	-
MFC09M1BW4	6.3 ± 3	-24.5 ± 3	-	-	-	-	-	-
MFC09M3BW3	6.3 ± 3	-24.5 ± 3	-	-	-	-	-	-
MFC09M3BW4	6.3 ± 3	-24.5 ± 3	-	-	-	-	-	-
MFC09M3FW0	6.3 ± 3	-24.5 ± 3	-	-	-	-	-	-
MFC09M3FW1	6.3 ± 3	-24.5 ± 3	-	-	-	-	-	-
MFC09M6BW3	6.3 ± 3	-24.5 ± 3	-	-	-	-	-	-
MFC09M6BW4	6.3 ± 3	-24.5 ± 3	-	-	-	-	-	-
MFC13M0BW3	6.3 ± 3	-24.5 ± 3	-	-	-	-	-	-
MFC13M0BW4	14.0 ± 3	-22.3 ± 3	-	-	-	-	-	-
MFC13M4FW0	6.3 ± 3	-24.5 ± 3	-	-	-	-	-	-
MFC13M4FW1	6.3 ± 3	-24.5 ± 3	-	-	-	-	-	-
MFC13M4FW2	14.0 ± 3	-22.3 ± 3	-	-	-	-	-	-
MFC13M4FW3	14.0 ± 3	-22.3 ± 3	-	-	-	-	-	-
MFC13M6BW2	6.3 ± 3	-24.5 ± 3	-	-	-	-	-	-
MFC13M6BW3	14.0 ± 3	-22.3 ± 3	-	-	-	-	-	-
MFC15D4FW0	6.3 ± 3	-24.5 ± 3	-	-	-	-	-	-
MFC15D4FW1	6.3 ± 3	-24.5 ± 3	-	-	-	-	-	-
MFC15D4FW2	14.0 ± 3	-22.3 ± 3	-	-	-	-	-	-
MFC15D4FW3	14.0 ± 3	-22.3 ± 3	-	-	-	-	-	-
MFC15M4FW0	6.3 ± 3	-24.5 ± 3	-	-	-	-	-	-

UNIVERSAL / MULTIFLEX ELECTRICAL SPECIFICATIONS

MODELS	Control Thermostat Calibration °F		Defrost Timer		Defrost Thermostat Calibration °F		Defrost Heater	
	Warm Position	Cold Position	Defrost Cycle (Min.)	Accum. Run Time (Hrs.)	Close	Open	Watts	Ohms
	Cut-In	Cut-Out						
MFC15M4FW1	6.3 ± 3	-24.5 ± 3	-	-	-	-	-	-
MFC15M4FW2	14.0 ± 3	-22.3 ± 3	-	-	-	-	-	-
MFC20M4FW0	6.3 ± 3	-24.5 ± 3	-	-	-	-	-	-
MFC20M4FW1	14.0 ± 3	-22.3 ± 3	-	-	-	-	-	-
MFC20M4FW2	14.0 ± 3	-22.3 ± 3	-	-	-	-	-	-
MFC23M4FW0	14.0 ± 3	-22.3 ± 3	-	-	-	-	-	-
MFC23M4FW1	14.0 ± 3	-22.3 ± 3	-	-	-	-	-	-
MFC25M4FW0	14.0 ± 3	-22.3 ± 3	-	-	-	-	-	-
MFC25M4FW1	14.0 ± 3	-22.3 ± 3	-	-	-	-	-	-
MFC25M4GW0	6.3 ± 3	-24.5 ± 3	-	-	-	-	-	-
MFC25M4GW1	14.0 ± 3	-22.3 ± 3	-	-	-	-	-	-
MFU09M2BW3	11.4 ± 3	-20.3 ± 3	-	-	-	-	-	-
MFU09M2BW4	11.4 ± 3	-20.3 ± 3	-	-	-	-	-	-
MFU09M2GW0	11.4 ± 3	-20.3 ± 3	-	-	-	-	-	-
MFU12M0BW4	11.4 ± 3	-20.3 ± 3	-	-	-	-	-	-
MFU12M0GW0	11.1 ± 3	-27.7 ± 3	-	-	-	-	-	-
MFU12M2BW4	11.4 ± 3	-20.3 ± 3	-	-	-	-	-	-
MFU12M2GW0	11.4 ± 3	-20.3 ± 3	-	-	-	-	-	-
MFU14D2FW0	11.4 ± 3	-20.3 ± 3	-	-	-	-	-	-
MFU14D2FW1	11.4 ± 3	-20.3 ± 3	-	-	-	-	-	-
MFU14D2GW0	11.4 ± 3	-20.3 ± 3	-	-	-	-	-	-
MFU14F1EW2	6.2 ± 3	-21.2 ± 3	-	-	-	-	-	-
MFU14F1GW0	6.2 ± 3	-21.2 ± 3	-	-	-	-	-	-
MFU14F1GW1	6.2 ± 3	-21.2 ± 3	-	-	-	-	-	-
MFU14F3BW6	6.2 ± 3	-21.2 ± 3	29.9 ± 3.6	12	30 ± 5	50 ± 5	400 ± 5%	33
MFU14F3GW0	6.2 ± 3	-21.2 ± 3	29.9 ± 3.6	12	30 ± 5	50 ± 5	400 ± 5%	33
MFU14F3GW1	6.2 ± 3	-21.2 ± 3	29.9 ± 3.6	12	30 ± 5	50 ± 5	400 ± 5%	33

UNIVERSAL / MULTIFLEX ELECTRICAL SPECIFICATIONS

MODELS	Control Thermostat Calibration °F		Defrost Timer		Defrost Thermostat Calibration °F		Defrost Heater	
	Warm Position	Cold Position	Defrost Cycle (Min.)	Accum. Run Time (Hrs.)	Close	Open	Watts	Ohms
	Cut-In	Cut-Out						
MFU14F7FW0	6.2 ± 3	-21.2 ± 3	29.9 ± 3.6	12	30 ± 5	50 ± 5	400 ± 5%	33
MFU14F7FW1	6.2 ± 3	-21.2 ± 3	29.9 ± 3.6	12	30 ± 5	50 ± 5	400 ± 5%	33
MFU14M2FW0	11.4 ± 3	-20.3 ± 3	-	-	-	-	-	-
MFU14M2FW1	11.4 ± 3	-20.3 ± 3	-	-	-	-	-	-
MFU16F3BW7	4.0 ± 2	-24.0 ± 2	29.9 ± 3.6	12	30 ± 5	50 ± 5	550 ± 5%	24
MFU16F7FW0	6.2 ± 3	-21.2 ± 3	29.9 ± 3.6	12	30 ± 5	50 ± 5	550 ± 5%	24
MFU16F7FW1	6.2 ± 3	-21.2 ± 3	29.9 ± 3.6	12	30 ± 5	50 ± 5	550 ± 5%	24
MFU17F3GW1	6.2 ± 3	-21.2 ± 3	29.9 ± 3.6	12	30 ± 5	50 ± 5	550 ± 5%	24
MFU17M3GW0	8.8 ± 3	-21.0 ± 3	-	-	-	-	-	-
MFU20F3BW5	6.2 ± 3	-21.2 ± 3	29.9 ± 3.6	12	30 ± 5	50 ± 5	550 ± 5%	24
MFU20F3BW6	6.2 ± 3	-21.2 ± 3	29.9 ± 3.6	12	30 ± 5	50 ± 5	550 ± 5%	24
MFU20F3GW0	6.2 ± 3	-21.2 ± 3	29.9 ± 3.6	12	30 ± 5	50 ± 5	550 ± 5%	24
MFU20F3GW1	6.2 ± 3	-21.2 ± 3	29.9 ± 3.6	12	30 ± 5	50 ± 5	550 ± 5%	24
MFU20F7FW0	6.2 ± 3	-21.2 ± 3	29.9 ± 3.6	12	30 ± 5	50 ± 5	550 ± 5%	24
MFU20F7FW1	6.2 ± 3	-21.2 ± 3	29.9 ± 3.6	12	30 ± 5	50 ± 5	550 ± 5%	24
MFU21M3GW0	8.8 ± 3	-21.0 ± 3	-	-	-	-	-	-

BROICH ELECTRICAL SPECIFICATIONS

F22CW2	1.0 ± 2	-31.4 ± 3	29.9 ± 3.6	12 *	30 ± 5	50 ± 5	550 ± 5%	24
F22CW3	1.0 ± 2	-31.4 ± 3	29.9 ± 3.6	2 *	30 ± 5	50 ± 5	550 ± 5%	24
F22CW4	1.0 ± 2	-31.4 ± 3	29.9 ± 3.6	2 *	30 ± 5	50 ± 5	550 ± 5%	24
F22CW5	1.0 ± 2	-31.4 ± 3	29.9 ± 3.6	2 *	30 ± 5	50 ± 5	550 ± 5%	24
F22CW6	1.0 ± 2	-31.4 ± 3	29.9 ± 3.6	2 *	30 ± 5	50 ± 5	550 ± 5%	24
R22CW1	35.7 ± 3	31.6 ± 3	29.9 ± 3.6	2 *	30 ± 5	50 ± 5	550 ± 5%	24
R22CW2	35.7 ± 3	31.6 ± 3	29.9 ± 3.6	2 *	30 ± 5	50 ± 5	550 ± 5%	24
R22CW4	35.7 ± 3	31.6 ± 3	29.9 ± 3.6	2 *	30 ± 5	50 ± 5	550 ± 5%	24
R22CW5	35.7 ± 3	31.6 ± 3	29.9 ± 3.6	2 *	30 ± 5	50 ± 5	550 ± 5%	24

* This model uses Clock Time

BROICH ELECTRICAL SPECIFICATIONS

MODELS	Control Thermostat Calibration °F		Defrost Timer		Defrost Thermostat Calibration °F		Defrost Heater	
	Warm Position	Cold Position	Defrost Cycle (Min.)	Accum. Run Time (Hrs.)	Close	Open	Watts	Ohms
	Cut-In	Cut-Out						
UL1293ECW8	11.4 ± 3	-20.3 ± 3	-	-	-	-	-	-
UL1793ECW7	8.8 ± 3	-21.0 ± 3	-	-	-	-	-	-
UL2030ECW12	4.0 ± 2	-24.0 ± 2	29.9 ± 3.6	12	30 ± 5	50 ± 5	550 ± 5%	24
UL2030ECW7	6.2 ± 3	-21.2 ± 3	29.9 ± 3.6	12	30 ± 5	50 ± 5	550 ± 5%	24
UL2100ECW0	8.8 ± 3	-21.0 ± 3	-	-	-	-	-	-
UL2100ECW1	8.8 ± 3	-21.0 ± 3	-	-	-	-	-	-
UL2494ECW8	8.5 ± 3	-21.0 ± 3	-	-	-	-	-	-
UL4000ECW1	8.8 ± 3	-21.0 ± 3	-	-	-	-	-	-
UL4000ECW3	8.8 ± 3	-21.0 ± 3	-	-	-	-	-	-
UL5000ECW3	8.5 ± 3	-21.0 ± 3	-	-	-	-	-	-
XF22CW0	1.0 ± 2	-31.4 ± 3	29.9 ± 3.6	12 *	30 ± 5	50 ± 5	550 ± 5%	24
XR22CW0	1.0 ± 2	-31.4 ± 3	29.9 ± 3.6	12 *	30 ± 5	50 ± 5	550 ± 5%	24

EDINA TECH ELECTRICAL SPECIFICATIONS

FMR5	46.6 ± 3	30.4 ± 3	-	-	-	-	-	-
FMW2	51.5 ± 3	24.9 ± 3	-	-	-	-	-	-
FMW3	51.5 ± 3	24.9 ± 3	-	-	-	-	-	-

TAPPAN ELECTRICAL SPECIFICATIONS

TFC05M4AW3	7.0 ± 3	-25.0 ± 3	-	-	-	-	-	-
TFC07M4CW2	7.0 ± 3	-25.0 ± 3	-	-	-	-	-	-
TFC09M4AW3	7.0 ± 3	-25.0 ± 3	-	-	-	-	-	-

VENEX INC. ELECTRICAL SPECIFICATIONS

ER142	8.5 ± 3	-21.2 ± 3	29.9 ± 3.6	12	30 ± 5	50 ± 5	400 ± 5%	33
ER143	8.5 ± 3	-21.2 ± 3	29.9 ± 3.6	12	30 ± 5	50 ± 5	400 ± 5%	33
ER145	8.5 ± 3	-21.2 ± 3	29.9 ± 3.6	12	30 ± 5	50 ± 5	400 ± 5%	33
VV204	4.0 ± 2	-24.0 ± 2	29.9 ± 3.6	12	30 ± 5	50 ± 5	550 ± 5%	24
VV205	4.0 ± 2	-24.0 ± 2	29.9 ± 3.6	12	30 ± 5	50 ± 5	400 ± 5%	33
VV207	4.0 ± 2	-24.0 ± 2	29.9 ± 3.6	12	30 ± 5	50 ± 5	400 ± 5%	33

* This model uses Clock Time

FRIGIDAIRE SYSTEM SPECIFICATIONS

MODELS	Compressor Type	Refrigerant (R134a) Oz.	Suction Pressure - PSIG				High Side PSIG (Last 1/3 of cycle)		Wattage Range (Last 1/3 of cycle)	
			Ambient 70°F		Ambient 90°F		70°F	90°F	70°F	90°F
			Cut-In	Cut-Out	Cut-In	Cut-Out				
FFC05M5CW2	EM45HER	5.5	12	0	12	0	120-130	155-165	85-95	85-95
FFC05M5CW3	EM45HER	5.5	12	0	12	0	120-130	155-165	85-95	85-95
FFC07M5CW2	EM45HER	7	12	0	12	0	120-130	155-165	85-95	85-95
FFC07M5CW3	EM45HER	7	12	0	12	0	120-130	155-165	85-95	85-95
FFC09M5CW2	EM45HER	7	12	0	12	0	120-130	155-165	85-95	85-95
FFC09M5CW3	EM45HER	8	12	0	12	0	120-130	155-165	85-95	85-95
FFC13D9EW1	EM60HSC	9	14	0	14	0	110-115	140-155	90-105	100-115
FFC13D9EW2	EM60HSC	9	14	0	14	0	110-115	140-155	90-105	100-115
FFC13M6CW2	EM60HSC	10	12	2	12	2	110-115	140-155	90-105	100-115
FFC15D9CW2	EM60HSC	10	12	2	12	2	110-115	140-155	90-105	100-115
FFC15M6CW2	EM60HSC	10	12	2	12	2	110-115	140-155	90-105	100-115
FFC20D7GW0	FGS70HA	11.5	12	2	12	2	110-115	140-155	90-105	100-115
FFC20D7GW1	FGS70HA	11.5	12	2	12	2	110-115	140-155	90-105	100-115
FFC20M7CW1	FGS70HA	11.5	12	2	12	2	110-115	140-155	90-105	100-115
FFU09M5CW2	EM45HER	6.5	15	0	15	0	100-110	140-150	80-90	85-95
FFU09M5GW0	EM30HNR	7	15	0	15	0	100-115	140-150	75-110	75-110
FFU12D9EW1	EM45HER	6.5	15	0	15	0	100-110	140-150	80-90	85-95
FFU12D9EW2	EM45HER	6.5	15	0	15	0	100-110	140-150	80-90	85-95
FFU12D9GW0	EM45HNR	7	15	0	15	0	100-115	140-150	75-110	75-110
FFU12M5CW2	EM45HER	6.5	15	0	15	0	100-110	140-150	80-90	85-95
FFU12M5GW0	EM45HNR	7	15	0	15	0	100-115	140-150	75-110	75-110
FFU14F9FW0	RG107-1-3642	5.5	14	0	14	0	125-140	165-180	125-135	135-145
FFU14F9FW1	RG107-1-3642	5.5	14	0	14	0	125-140	165-180	125-135	135-145
FFU14F9GW0	EM55HNR	6.5	14	0	14	0	110-120	150-160	110-120	115-125
FFU14F9GW1	EM55HNR	6.5	14	0	14	0	110-120	150-160	110-120	115-125
FFU14M8CW2	EM60HSC	7	15	0	15	0	100-110	140-150	80-90	85-95
FFU14M8GW0	EM55HNR	8	15	0	15	0	100-115	140-150	75-110	75-110
FFU16F9FW0	RG108-1-3093	7.5	14	0	14	0	115-130	160-175	140-155	145-160

FRIGIDAIRE SYSTEM SPECIFICATIONS

MODELS	Compressor Type	Refrigerant (R134a) Oz.	Suction Pressure - PSIG				High Side PSIG (Last 1/3 of cycle)		Wattage Range (Last 1/3 of cycle)	
			Ambient 70°F		Ambient 90°F		70°F	90°F	70°F	90°F
			Cut-In	Cut-Out	Cut-In	Cut-Out				
FFU16F9FW1	RG108-1-3093	7.5	14	0	14	0	115-130	160-175	140-155	145-160
FFU17D9GW0	RF107-1-3665	8	14	0	14	0	115-125	150-160	120-130	130-140
FFU17F9GW0	RF107-1-3665	7.5	14	0	14	0	110-125	150-165	135-160	145-165
FFU17F9GW1	RF107-1-3665	7.5	14	0	14	0	110-125	150-165	135-160	145-165
FFU17M8GW0	RF107-1-3665	8	14	0	14	0	115-125	150-160	120-130	130-140
FFU20F9FW0	RG109-1-3089	7	14	0	14	0	120-135	160-175	150-165	160-175
FFU20F9FW1	RG109-1-3089	7	14	0	14	0	120-135	160-175	150-165	160-175
FFU20F9GW0	RF108-1-3666	7	14	0	14	0	110-125	150-165	135-160	145-160
FFU20F9GW1	RF108-1-3666	7	14	0	14	0	110-125	150-165	135-160	145-160
FFU20G9FW0	RG109-1-3089	7	14	0	14	0	120-135	160-175	150-165	160-175
FFU20G9FW1	RG109-1-3644	7	14	0	14	0	120-135	160-175	150-165	160-175
FFU20G9GW0	RF108-1-3666	7	14	0	14	0	110-125	150-165	135-160	145-165
FFU20G9GW1	RF108-1-3666	7	14	0	14	0	110-125	150-165	135-160	145-165
FFU21M8GW0	RF107-1-3665	9	14	0	14	0	115-125	150-160	120-130	130-140

GIBSON SYSTEM SPECIFICATIONS

GFC05M3EW1	EM45HER	5.5	12	0	12	0	120-130	155-165	85-95	85-95
GFC05M3EW2	EM45HER	5.5	14	0	14	0	115-130	160-175	140-155	145-160
GFC07M3EW1	EM45HER	7	12	0	12	0	120-130	155-165	85-95	85-95
GFC07M3EW2	EM45HER	7	12	0	12	0	120-130	155-165	85-95	85-95
GFC09M3EW1	EM45HER	8	12	0	12	0	120-130	155-165	85-95	85-95
GFC09M3EW2	EM45HER	8	12	0	12	0	120-130	155-165	85-95	85-95
GFC15D4GW0	EM60HSC	10	15	0	15	0	100-115	140-150	75-110	75-110
GFC15D4GW1	EM60HSC	10	14	0	14	0	100-115	140-155	90-105	100-115
GFC15M4AW4	EM60HSC	10	12	2	12	2	100-115	140-155	90-105	100-115
GFC20M4GW0	FGS70HA	11.5	15	0	15	0	105-120	140-155	30-45	45-60
GFC20M4GW1	FGS70HA	11.5	14	0	14	0	100-115	140-155	90-105	100-115
GFU12M2AW6	EM45HER	6.5	15	0	15	0	100-110	140-150	80-90	85-95

GIBSON SYSTEM SPECIFICATIONS

MODELS	Compressor Type	Refrigerant (R134a) Oz.	Suction Pressure - PSIG				High Side PSIG (Last 1/3 of cycle)		Wattage Range (Last 1/3 of cycle)	
			Ambient 70°F		Ambient 90°F		70°F	90°F	70°F	90°F
			Cut-In	Cut-Out	Cut-In	Cut-Out				
GFU12M2GW0	EN45HNR	7	15	0	15	0	100-115	140-150	75-110	75-110
GFU14M3AW7	EM160HSC	7	15	0	15	0	105-120	140-155	100-110	105-115
GFU14M3GW0	EM55HNR	8	15	0	15	0	100-115	140-150	75-110	75-110
GFU16F7FW0	RG108-1-3093	7.5	14	0	14	0	120-135	160-175	150-165	160-175
GFU16F7FW1	RG108-1-3093	7.5	14	0	14	0	120-135	160-175	150-165	160-175
GFU17F7GW0	RF107-1-3665	7.5	14	0	14	0	110-125	150-165	135-160	145-165
GFU17F7GW1	RF107-1-3665	7.5	14	0	14	0	110-125	150-165	135-160	145-165
GFU17M4GW0	RF107-1-3665	8	14	0	14	0	115-125	150-160	120-130	130-140
GFU20F7FW0	RG109-1-3644	7	14	0	14	0	100-115	140-155	120-130	125-135
GFU20F7FW0	RG109-1-3644	7	14	0	14	0	120-135	160-175	150-165	160-175
GFU20F7GW0	RF108-1-3666	7	14	0	14	0	115-125	150-160	120-130	130-140
GFU20F7GW1	RF108-1-3666	7	14	0	14	0	110-125	150-165	135-160	145-165
GFU21D9FW0	RG107-1-3642	9	12	0	12	0	120-130	155-165	85-95	85-95
GFU21M4GW0	RF107-1-3665	9	12	2	12	2	100-115	140-155	90-105	100-115

UNIVERSAL / MULTIFLEX SYSTEM SPECIFICATIONS

MFC05M0BW3	EM145HER	5.5	12	0	12	0	120-130	155-165	85-95	85-95
MFC05M0BW4	EM145HER	5.5	12	0	12	0	120-130	155-165	85-95	85-95
MFC05M1FW0	EM145HER	5.5	12	0	12	0	120-130	155-165	85-95	85-95
MFC05M1FW1	EM145HER	5.5	12	0	12	0	120-130	155-165	85-95	85-95
MFC05M3BW3	EM145HER	5.5	12	0	12	0	120-130	155-165	85-95	85-95
MFC05M3BW4	EM145HER	5.5	12	0	12	0	120-130	155-165	85-95	85-95
MFC07M1BW3	EM145HER	7	12	0	12	0	120-130	155-165	85-95	85-95
MFC07M1BW4	EM145HER	7	12	0	12	0	120-130	155-165	85-95	85-95
MFC07M3BW3	EM145HER	7	12	0	12	0	120-130	155-165	85-95	85-95
MFC07M3BW4	EM145HER	7	12	0	12	0	120-130	155-165	85-95	85-95
MFC07M3FW0	EM145HER	7	12	0	12	0	120-130	155-165	85-95	85-95
MFC07M3FW1	EM145HER	7	12	0	12	0	120-130	155-165	85-95	85-95

UNIVERSAL / MULTIFLEX SYSTEM SPECIFICATIONS

MODELS	Compressor Type	Refrigerant (R134a) Oz.	Suction Pressure - PSIG				High Side PSIG (Last 1/3 of cycle)		Wattage Range (Last 1/3 of cycle)	
			Ambient 70°F		Ambient 90°F		70°F	90°F	70°F	90°F
			Cut-In	Cut-Out	Cut-In	Cut-Out				
MFC09M1BW3	EMI45HER	8	12	0	12	0	120-130	155-165	85-95	85-95
MFC09M1BW4	EMI45HER	8	12	0	12	0	120-130	155-165	85-95	85-95
MFC09M3BW3	EMI45HER	8	12	0	12	0	120-130	155-165	85-95	85-95
MFC09M3BW4	EMI45HER	8	12	0	12	0	120-130	155-165	85-95	85-95
MFC09M3FW0	EMI45HER	8	12	0	12	0	120-130	155-165	85-95	85-95
MFC09M3FW1	EMI45HER	8	12	0	12	0	120-130	155-165	85-95	85-95
MFC09M6BW3	EMI45HER	8	12	0	12	0	120-130	155-165	85-95	85-95
MFC09M6BW4	EMI45HER	8	12	0	12	0	120-130	155-165	85-95	85-95
MFC13M0BW3	EMI60HSC	9	12	2	12	2	110-115	140-155	90-105	100-115
MFC13M0BW4	EMI60HSC	9	14	0	14	0	100-115	140-155	90-105	100-115
MFC13M4FW0	EMI60HSC	9	12	2	12	2	110-115	140-155	90-105	100-115
MFC13M4FW1	EMI60HSC	9	12	2	12	2	110-115	140-155	90-105	100-115
MFC13M4FW2	EMI60HSC	9	12	2	12	2	110-115	140-155	90-105	100-115
MFC13M4FW3	EMI60HSC	9	14	0	14	0	110-115	140-155	90-105	100-115
MFC13M6BW2	EMI60HSC	9	12	2	12	2	110-115	140-155	90-105	100-115
MFC13M6BW3	EMI60HSC	9	14	0	14	0	110-115	140-155	90-105	100-115
MFC15D4FW0	EMI60HSC	10	12	2	12	2	110-115	140-155	90-105	110-115
MFC15D4FW1	EMI60HSC	10	12	2	12	2	110-115	140-155	90-105	100-115
MFC15D4FW2	EMI60HSC	10	12	2	12	2	110-115	140-155	90-105	110-115
MFC15D4FW3	EMI60HSC	10	12	2	12	2	110-115	140-155	90-105	110-115
MFC15M3BW2	EMI60HSC	10	12	2	12	2	110-115	140-155	90-105	110-115
MFC15M4FW0	EMI60HSC	10	12	2	12	2	110-115	140-155	90-105	110-115
MFC15M4FW1	EMI60HSC	10	12	2	12	2	110-115	140-155	90-105	110-115
MFC15M4FW2	EMI60HSC	9	14	0	14	0	110-115	140-155	90-105	110-115
MFC20M4FW0	FSG70HA	11.5	12	0	12	0	105-120	140-155	115-130	115-135
MFC20M4FW1	FSG80HA	11.5	12	0	12	0	105-120	140-155	115-130	115-135
MFC20M4FW2	FSG70HA	11.5	15	0	15	0	105-120	140-155	115-130	115-135

UNIVERSAL / MULTIFLEX SYSTEM SPECIFICATIONS

MODELS	Compressor Type	Refrigerant (R134a) Oz.	Suction Pressure - PSIG				High Side PSIG (Last 1/3 of cycle)		Wattage Range (Last 1/3 of cycle)	
			Ambient 70°F		Ambient 90°F		70°F	90°F	70°F	90°F
			Cut-In	Cut-Out	Cut-In	Cut-Out				
MFC23M4FW0	FSG70HA	12	12	0	12	0	105-120	140-155	115-130	115-135
MFC23M4FW1	FSG70HA	12	12	0	12	0	105-120	140-155	115-130	115-135
MFC25M4FW0	FSG70HA	13	12	0	12	0	105-120	140-155	115-130	115-135
MFC25M4FW1	FSG70HA	13	12	0	12	0	105-120	140-155	115-130	115-135
MFC25M4GW0	FSG70HA	13	12	0	12	0	105-120	140-155	115-130	115-135
MFC25M4GW1	FSG70HA	13	15	0	15	0	105-120	140-155	115-130	115-135
MFU09M2BW3	EM45HER	6.5	15	0	15	0	100-110	140-150	80-90	85-95
MFU09M2BW4	EM45HER	6.5	15	0	15	0	100-110	140-150	80-90	85-95
MFU09M2GW0	EM30HNR	7	15	0	15	0	100-115	140-150	75-110	75-110
MFU12M0BW4	EM45HER	6.5	15	0	15	0	100-110	140-150	80-90	85-95
MFU12M0GW0	EM45HNR	7	15	0	15	0	100-115	140-150	75-110	75-110
MFU12M2BW4	EM45HER	6.5	15	0	15	0	100-110	140-150	80-90	85-95
MFU12M2GW0	EM45HNR	7	15	0	15	0	100-115	140-150	75-110	75-110
MFU14D2FW0	EM60HSC	7	15	0	15	0	105-120	140-155	100-110	105-115
MFU14D2FW1	EM60HSC	7	15	0	15	0	105-120	140-155	100-110	105-115
MFU14D2GW0	EM55HNR	8	15	0	15	0	105-120	140-155	100-110	105-115
MFU14F1EW2	RG107-1-3642	5.5	14	0	14	0	125-140	165-180	125-135	135-145
MFU14F1GW0	EM55HNR	6.5	14	0	14	0	110-125	150-160	110-120	115-125
MFU14F1GW1	EM55HNR	6.5	14	0	14	0	110-125	150-160	110-120	115-125
MFU14F3BW6	RG107-1-3642	5.5	14	0	14	0	125-140	165-180	125-135	135-145
MFU14F3GW0	EM55HNR	6.5	14	0	14	0	110-125	150-160	110-120	115-125
MFU14F3GW1	RG107-1-3642	5.5	14	0	14	0	125-140	165-180	125-135	135-145
MFU14F7FW0	RG107-1-3642	5.5	14	0	14	0	125-140	165-180	125-135	135-145
MFU14F7FW1	RG107-1-3642	5.5	14	0	14	0	125-140	165-180	125-135	135-145
MFU14M2FW0	EM60HSC	7	15	0	15	0	105-120	140-155	100-110	105-115
MFU14M2FW1	EM60HSC	7	15	0	15	0	105-120	140-155	100-110	105-115
MFU16F3BW7	RG108-1-3093	7.5	14	0	14	0	115-130	160-175	140-155	145-160

UNIVERSAL / MULTIFLEX SYSTEM SPECIFICATIONS

MODELS	Compressor Type	Refrigerant (R134a) Oz.	Suction Pressure - PSIG				High Side PSIG (Last 1/3 of cycle)		Wattage Range (Last 1/3 of cycle)	
			Ambient 70°F		Ambient 90°F		70°F	90°F	70°F	90°F
			Cut-In	Cut-Out	Cut-In	Cut-Out				
MFU16F7FW0	RG108-1-3093	7.5	14	0	14	0	115-130	160-175	140-155	145-160
MFU16F7FW1	RG108-1-3093	7.5	14	0	14	0	120-135	160-175	150-165	160-175
MFU17F3GW1	RF107-1-3665	7.5	14	0	14	0	110-125	150-165	35-45	45-60
MFU17M3GW0	RF107-1-3665	8	14	0	14	0	115-125	150-160	120-130	130-140
MFU20F3BW5	RG109-1-3644	7	14	0	14	0	120-135	160-175	150-165	160-175
MFU20F3BW6	RG109-1-3644	7	14	0	14	0	120-135	160-175	150-165	160-175
MFU20F3GW0	RF108-1-3666	7	14	0	14	0	110-125	150-165	35-45	45-60
MFU20F3GW1	RF108-1-3666	7	14	0	14	0	110-125	150-165	35-45	45-60
MFU20F7FW0	RF108-1-3666	7	14	0	14	0	120-135	160-175	150-165	160-175
MFU20F7FW1	RF108-1-3666	7	14	0	14	0	120-135	160-175	150-165	160-175
MFU21M3GW0	RF107-1-3665	9	14	0	14	0	115-125	150-160	120-130	130-140

BROICH SYSTEM SPECIFICATIONS

F22CW2	RG213-1-3072	9.5	*	*	*	*	*	*	*	*	*
F22CW3	RG213-1-3072	9.5	*	*	*	*	*	*	*	*	*
F22CW4	RG213-1-3072	9.5	*	*	*	*	*	*	*	*	*
F22CW5	RG213-1-3072	9.5	*	*	*	*	*	*	*	*	*
F22CW6	RG213-1-3072	9.5	*	*	*	*	*	*	*	*	*
R22CW1	RF107-1-3665	9.5	*	*	*	*	*	*	*	*	*
R22CW2	RF107-1-3665	9.5	*	*	*	*	*	*	*	*	*
R22CW4	RF107-1-3665	9.5	*	*	*	*	*	*	*	*	*
R22CW5	RF107-1-3665	9.5	*	*	*	*	*	*	*	*	*
UL1293ECW8	EMI45HER	6.5	15	0	15	0	100-110	140-150	80-90	85-95	
UL1793ECW7	RF107-1-3665	8	14	0	14	0	100-115	140-155	120-130	125-135	
UL2030ECW12	RF108-1-3666	7	14	0	14	0	110-125	150-165	135-160	145-165	
UL2030ECW7	RF108-1-3666	7	14	0	14	0	120-135	160-175	150-165	160-170	
UL2100ECW0	RF107-1-3665	9	14	0	14	0	100-115	140-155	120-130	125-135	

* Information not available

BROICH SYSTEM SPECIFICATIONS

MODELS	Compressor Type	Refrigerant (R134a) Oz.	Suction Pressure - PSIG				High Side PSIG (Last 1/3 of cycle)		Wattage Range (Last 1/3 of cycle)	
			Ambient 70°F		Ambient 90°F		70°F	90°F	70°F	90°F
			Cut-In	Cut-Out	Cut-In	Cut-Out				
UL2100ECW1	RF107-1-3665	9	14	0	14	0	115-125	150-160	120-130	130-140
UL2494ECW8	RG107-1-3642	9	14	0	14	0	115-125	150-160	120-130	130-140
UL4000ECW1	RF207-1-3663	9.5	14	0	14	0	100-115	140-155	120-130	125-135
UL4000ECW3	RF207-1-3663	9.5	14	0	14	0	115-125	150-160	120-130	130-140
UL5000ECW3	RF207-1-3663	9.5	14	0	14	0	115-125	150-160	120-130	130-140
XF22CW0	RG211-12-3684	9.5	*	*	*	*	*	*	*	*
XR22CW0	RF207-12-3067	9.5	*	*	*	*	*	*	*	*

EDINA TECH SYSTEM SPECIFICATIONS

FMR5	EM45HER	5	37	1	37	1	90-110	120-140	90-110	90-110
FMW2	EM45HER	4.5	45	4	-1	-2	90-110	125-135	65-75	70-80
FMW3	EM45HER	4.5	45	4	-1	-2	90-110	125-135	65-75	70-80

TAPPAN SYSTEM SPECIFICATIONS

TFC05M4AW3	EM45HER	5.5	12	0	12	0	120-130	155-165	85-95	85-95
TFC07M4CW2	EM45HER	7	12	0	12	0	120-130	155-165	85-95	85-95
TFC09M4AW3	EM45HER	8	12	0	12	0	120-130	155-165	85-95	85-95

VENEX INC. SYSTEM SPECIFICATIONS

ER142	RG213-1-3072	6.5	-4	-20	-3	-22	130-140	175-190	250-260	250-260
ER143	RG213-1-3072	6.5	-4	-20	-3	-22	130-140	175-190	250-260	250-260
ER145	RG213-1-3072	6.5	-4	-20	-3	-22	130-140	175-190	250-260	250-260
VV204	RG109-1-3644	7	14	0	14	0	120-135	160-175	150-165	160-175
VV205	RG109-1-3644	7	14	0	14	0	120-135	160-175	150-165	160-175
VV207	RG109-1-3644	7	14	0	14	0	120-135	160-175	150-165	160-175

* Information not available

FRIGIDAIRE SCHEMATIC INDEX LIST

Model	Service Data Sheet	Electrical Diagram	Relay/Overload	System Schematic
FFC05M5CW2	216372500	EC1 / Page 24	C9 / Page 28	SS3 / Page 29
FFC05M5CW3	216372500	EC1 / Page 24	C9 / Page 28	SS3 / Page 29
FFC07M5CW2	216372500	EC1 / Page 24	C9 / Page 28	SS3 / Page 29
FFC07M5CW3	216372500	EC1 / Page 24	C9 / Page 28	SS3 / Page 29
FFC09M5CW2	216372500	EC1 / Page 24	C9 / Page 28	SS3 / Page 29
FFC09M5CW3	216372500	EC1 / Page 24	C9 / Page 28	SS3 / Page 29
FFC13D9EW1	216419000	EC1 / Page 24	C1 / Page 28	SS3 / Page 29
FFC13D9EW2	216616200	EC9 / Page 25	C1 / Page 28	SS6 / Page 30
FFC13M6CW2	216419100	EC1 / Page 24	C1 / Page 28	SS1 / Page 29
FFC15D9CW2	216419000	EC1 / Page 24	C1 / Page 28	SS1 / Page 29
FFC15M6CW2	216419100	EC1 / Page 24	C1 / Page 28	SS1 / Page 29
FFC20D7GW0	216601700	EC25 / Page 26	C1 / Page 28	SS6 / Page 30
FFC20D7GW1	216601700	EC25 / Page 26	C1 / Page 28	SS6 / Page 30
FFC20M7CW1	216419100	EC1 / Page 24	C1 / Page 28	SS1 / Page 29
FFU09M5CW2	216415800	EC2 / Page 24	C23 / Page 28	SS1 / Page 29
FFU09M5GW0	216576600	EC40 / Page 26	C23 / Page 28	SS1 / Page 29
FFU12D9EW1	216464300	EC21 / Page 25	C23 / Page 28	SS5 / Page 29
FFU12D9EW2	216464300	EC21 / Page 25	C23 / Page 28	SS5 / Page 29
FFU12D9GW0	216607800	EC42 / Page 27	C23 / Page 28	SS5 / Page 29
FFU12M5CW2	216415800	EC2 / Page 24	C23 / Page 28	SS1 / Page 29
FFU12M5GW0	216576600	EC40 / Page 26	C23 / Page 28	SS1 / Page 29
FFU14F9FW0	216418400	EC3 / Page 24	C1 / Page 28	SS8 / Page 30
FFU14F9FW1	216418400	EC3 / Page 24	C1 / Page 28	SS8 / Page 30
FFU14F9GW0	216583900	EC41 / Page 27	C9 / Page 28	SS8 / Page 30
FFU14F9GW1	216583900	EC41 / Page 27	C9 / Page 28	SS8 / Page 30
FFU14M8CW2	216416400	EC2 / Page 24	C2 / Page 28	SS1 / Page 29
FFU14M8GW0	216576600	EC40 / Page 26	C23 / Page 28	SS1 / Page 29
FFU16F9FW0	216418800	EC3 / Page 24	C1 / Page 28	SS8 / Page 30

FRIGIDAIRE SCHEMATIC INDEX LIST

Model	Service Data Sheet	Electrical Diagram	Relay/Overload	System Schematic
FFU16F9FW1	216418800	EC3 / Page 24	C1 / Page 28	SS8 / Page 30
FFU17D9GW0	216594400	EC42 / Page 27	C6 / Page 28	SS5 / Page 29
FFU17F9GW0	216569300	EC41 / Page 27	C5 / Page 28	SS8 / Page 30
FFU17F9GW1	216569300	EC41 / Page 27	C5 / Page 28	SS8 / Page 30
FFU17M8GW0	216569200	EC40 / Page 26	C6 / Page 28	SS1 / Page 29
FFU20F9FW0	216418700	EC3 / Page 24	C1 / Page 28	SS8 / Page 30
FFU20F9FW1	216418700	EC3 / Page 24	C1 / Page 28	SS8 / Page 30
FFU20F9GW0	216602700	EC58 / Page 27	C5 / Page 28	SS8 / Page 30
FFU20F9GW1	216602700	EC58 / Page 27	C5 / Page 28	SS8 / Page 30
FFU20G9FW0	216502800	EC17 / Page 25	C1 / Page 28	SS8 / Page 30
FFU20G9FW1	216502800	EC17 / Page 25	C1 / Page 28	SS8 / Page 30
FFU20G9GW0	216602700	EC58 / Page 27	C5 / Page 28	SS8 / Page 30
FFU20G9GW1	216602700	EC58 / Page 27	C5 / Page 28	SS8 / Page 30
FFU21M8GW0	216569200	EC40 / Page 26	C6 / Page 28	SS1 / Page 29

GIBSON SCHEMATIC INDEX LIST

GFC05M3EW1	216372600	EC5 / Page 24	C9 / Page 28	SS3 / Page 29
GFC05M3EW2	216418900	EC3 / Page 24	C1 / Page 28	SS8 / Page 30
GFC07M3EW1	216372600	EC5 / Page 24	C9 / Page 28	SS3 / Page 29
GFC07M3EW2	216372600	EC5 / Page 24	C9 / Page 28	SS3 / Page 29
GFC09M3EW1	216372600	EC5 / Page 24	C9 / Page 28	SS3 / Page 29
GFC09M3EW2	216372600	EC5 / Page 24	C9 / Page 28	SS3 / Page 29
GFC15D4GW0	216576600	EC40 / Page 26	C23 / Page 28	SS1 / Page 29
GFC15D4GW1	216616000	EC25 / Page 26	C1 / Page 28	SS9 / Page 30
GFC15M4AW4	216419200	EC1 / Page 24	C1 / Page 28	SS1 / Page 29
GFC20M4GW0	216569300	EC1 / Page 24	C1 / Page 28	SS1 / Page 29
GFC20M4GW1	216616100	EC1 / Page 24	C1 / Page 28	SS1 / Page 29
GFU12M2AW6	216416000	EC2 / Page 24	C23 / Page 28	SS1 / Page 29
GFU12M2GW0	216576600	EC40 / Page 26	C23 / Page 28	SS1 / Page 29

GIBSON SCHEMATIC INDEX LIST

Model	Electrical Diagram	Service Data Sheet	Relay/Overload	System Schematic
GFU14M3AW7	EC2 / Page 24	216416500	C2 / Page 28	SS1 / Page 29
GFU14M3GW0	EC40 / Page 26	216576600	C23 / Page 28	SS1 / Page 29
GFU16F7FW0	EC3 / Page 24	216418500	C1 / Page 28	SS8 / Page 30
GFU16F7FW1	EC3 / Page 24	216418700	C1 / Page 28	SS8 / Page 30
GFU17F7GW0	EC41 / Page 27	216569300	C5 / Page 28	SS8 / Page 30
GFU17F7GW1	EC40 / Page 26	216569200	C6 / Page 28	SS1 / Page 29
GFU17M4GW0	EC40 / Page 26	216569200	C6 / Page 28	SS1 / Page 29
GFU20F7FW0	EC27 / Page 26	216504900	C2 / Page 28	SS5 / Page 29
GFU20F7FW1	EC3 / Page 24	216418700	C1 / Page 28	SS8 / Page 30
GFU20F7GW0	EC40 / Page 26	216569200	C6 / Page 28	SS1 / Page 29
GFU20F7GW1	EC41 / Page 27	216569300	C5 / Page 28	SS8 / Page 30
GFU21D9FW0	EC5 / Page 24	216372600	C9 / Page 28	SS3 / Page 29
GFU21M4GW0	EC40 / Page 26	216569200	C6 / Page 28	SS1 / Page 29
GFU21M4GW1	EC40 / Page 26	216495800	C1 / Page 28	SS9 / Page 30

UNIVERSAL / MULTIFLEX SCHEMATIC INDEX LIST

MFC05M0BW3	EC1 / Page26	216372500	C9 / Page 28	SS3 / Page 29
MFC05M0BW4	EC1 / Page26	216372500	C9 / Page 28	SS3 / Page 29
MFC05MIFW0	EC1 / Page26	216372500	C9 / Page 28	SS3 / Page 29
MFC05MIFW1	EC1 / Page26	216372500	C9 / Page 28	SS3 / Page 29
MFC05M3BW3	EC1 / Page26	216372500	C9 / Page 28	SS3 / Page 29
MFC05M3BW4	EC1 / Page26	216372500	C9 / Page 28	SS3 / Page 29
MFC07M1BW3	EC1 / Page26	216372500	C9 / Page 28	SS3 / Page 29
MFC07M1BW4	EC1 / Page26	216372500	C9 / Page 28	SS3 / Page 29
MFC07M3BW3	EC1 / Page26	216372500	C9 / Page 28	SS3 / Page 29
MFC07M3BW4	EC1 / Page26	216372500	C9 / Page 28	SS3 / Page 29
MFC07M3FW0	EC1 / Page26	216372500	C9 / Page 28	SS3 / Page 29
MFC07M3FW1	EC1 / Page26	216372500	C9 / Page 28	SS3 / Page 29
MFC09M1BW3	EC1 / Page26	216372500	C9 / Page 28	SS3 / Page 29

UNIVERSAL / MULTIFLEX SCHEMATIC INDEX LIST

Model	Service Data Sheet	Electrical Diagram	Relay/Overload	System Schematic
MFC09M1BW4	216372500	EC1 / Page 24	C9 / Page 28	SS3 / Page 29
MFC09M3BW3	216372500	EC1 / Page 24	C9 / Page 28	SS3 / Page 29
MFC09M3BW4	216372500	EC1 / Page 24	C9 / Page 28	SS3 / Page 29
MFC09M3FW0	216372500	EC1 / Page 24	C9 / Page 28	SS3 / Page 29
MFC09M3FW1	216372500	EC1 / Page 24	C9 / Page 28	SS3 / Page 29
MFC09M6BW3	216372500	EC1 / Page 24	C9 / Page 28	SS3 / Page 29
MFC09M6BW4	216372500	EC1 / Page 24	C9 / Page 28	SS3 / Page 29
MFC13M0BW3	216419100	EC1 / Page 24	C1 / Page 28	SS3 / Page 29
MFC13M0BW4	216615900	EC1 / Page 24	C1 / Page 28	SS3 / Page 29
MFC13M4FW0	216419100	EC1 / Page 24	C1 / Page 28	SS3 / Page 29
MFC13M4FW1	216419100	EC1 / Page 24	C1 / Page 28	SS3 / Page 29
MFC13M4FW2	216419100	EC1 / Page 24	C1 / Page 28	SS3 / Page 29
MFC13M4FW3	216615900	EC1 / Page 24	C1 / Page 28	SS1 / Page 29
MFC13M6BW2	216419100	EC1 / Page24	C1 / Page 28	SS3 / Page 29
MFC13M6BW3	216615900	EC1 / Page 24	C1 / Page 28	SS1 / Page 29
MFC15D4FW0	216495800	EC25 / Page 26	C1 / Page 28	SS4 / Page 29
MFC15D4FW1	216495800	EC25 / Page 26	C1 / Page 28	SS4 / Page 29
MFC15D4FW2	216495800	EC25 / Page 26	C1 / Page 28	SS4 / Page 29
MFC15D4FW3	216616000	EC25 / Page 26	C1 / Page 28	SS9 / Page 30
MFC15M3BW2	216439800	EC1 / Page 24	C1 / Page 28	SS1 / Page 29
MFC15M4FW0	216419100	EC1 / Page 24	C1 / Page 28	SS1 / Page 29
MFC15M4FW1	216419100	EC1 / Page 24	C1 / Page 28	SS1 / Page 29
MFC15M4FW2	216615900	EC1 / Page 24	C1 / Page 28	SS1 / Page 29
MFC20M4FW0	216498300	EC1 / Page 24	C1 / Page 28	SS1 / Page 29
MFC20M4FW1	216498300	EC1 / Page 24	C1 / Page 28	SS1 / Page 29
MFC20M4FW2	216616100	EC1 / Page 24	C1 / Page 28	SS1 / Page 29
MFC23M4FW0	216498300	EC1 / Page 24	C1 / Page 28	SS1 / Page 29
MFC23M4FW1	216498300	EC1 / Page 24	C1 / Page 28	SS1 / Page 29

UNIVERSAL / MULTIFLEX SCHEMATIC INDEX LIST

Model	Service Data Sheet	Electrical Diagram	Relay/Overload	System Schematic
MFC25M4FW0	216498300	EC1 / Page 24	C1 / Page 28	SS1 / Page 29
MFC25M4FW1	216498300	EC1 / Page 24	C1 / Page 28	SS1 / Page 29
MFC25M4GW0	216498300	EC1 / Page 24	C1 / Page 28	SS1 / Page 29
MFC25M4GW1	216616100	EC1 / Page 24	C1 / Page 28	SS1 / Page 29
MFU09M2BW3	216415800	EC2 / Page 24	C23 / Page 28	SS1 / Page 29
MFU09M2BW4	216415800	EC2 / Page 24	C23 / Page 28	SS1 / Page 29
MFU09M2GW0	216576600	EC1 / Page 24	C1 / Page 28	SS1 / Page 29
MFU12M0BW4	216415800	EC2 / Page 24	C23 / Page 28	SS1 / Page 29
MFU12M0GW0	216576700	EC40 / Page 26	C23 / Page 28	SS1 / Page 29
MFU12M2BW4	216415800	EC2 / Page 24	C23 / Page 28	SS1 / Page 29
MFU12M2GW0	216576700	EC40 / Page 26	C23 / Page 28	SS1 / Page 29
MFU14D2FW0	216499900	EC26 / Page 26	C23 / Page 28	SS5 / Page 29
MFU14D2FW1	216499900	EC26 / Page 26	C23 / Page 28	SS5 / Page 29
MFU14D2GW0	216583500	EC26 / Page 26	C23 / Page 28	SS5 / Page 29
MFU14F1EW2	216418400	EC23 / Page 26	C1 / Page 28	SS8 / Page 30
MFU14F1GW0	216583900	EC41 / Page 27	C9 / Page 28	SS8 / Page 30
MFU14F1GW1	216583900	EC41 / Page 27	C9 / Page 28	SS8 / Page 30
MFU14F3BW6	216418400	EC23 / Page 26	C1 / Page 28	SS8 / Page 30
MFU14F3GW0	216583900	EC41 / Page 27	C9 / Page 28	SS8 / Page 30
MFU14F3GW1	216583900	EC23 / Page 26	C1 / Page 28	SS8 / Page 30
MFU14F7FW0	216583900	EC23 / Page 26	C1 / Page 28	SS8 / Page 30
MFU14F7FW1	216583900	EC23 / Page 26	C1 / Page 28	SS8 / Page 30
MFU14M2FW0	216416400	EC23 / Page 26	C2 / Page 28	SS1 / Page 29
MFU14M2FW1	216416400	EC23 / Page 26	C2 / Page 28	SS1 / Page 29
MFU16F3BW7	216418800	EC3 / Page 24	C1 / Page 28	SS8 / Page 30
MFU16F7FW0	216418800	EC3 / Page 24	C1 / Page 28	SS8 / Page 30
MFU16F7FW1	216418700	EC3 / Page 24	C1 / Page 28	SS8 / Page 30
MFU17F3GW1	216569300	EC41 / Page 27	C5 / Page 28	SS8 / Page 30

UNIVERSAL / MULTIFLEX SCHEMATIC INDEX LIST

Model	Service Data Sheet	Electrical Diagram	Relay/Overload	System Schematic
MFU17M3GW0	216569200	EC40 / Page 26	C6 / Page 28	SS1 / Page 29
MFU20F3BW5	216418700	EC3 / Page 24	C1 / Page 28	SS8 / Page 30
MFU20F3BW6	216418700	EC3 / Page 24	C1 / Page 28	SS8 / Page 30
MFU20F3GW0	216569300	EC41 / Page 27	C5 / Page 28	SS8 / Page 30
MFU20F3GW1	216569300	EC41 / Page 27	C5 / Page 28	SS8 / Page 30
MFU20F7FW0	216418700	EC3 / Page 24	C1 / Page 28	SS8 / Page 30
MFU20F7FW1	216418700	EC3 / Page 24	C1 / Page 28	SS8 / Page 30
MFU21M3GW0	216569200	EC40 / Page 26	C6 / Page 30	SS1 / Page 29

BROICH SCHEMATIC INDEX LIST

F22CW2	216613400	*	*	*
F22CW3	216613400	*	*	*
F22CW4	216613400	*	*	*
F22CW5	216613400	*	*	*
F22CW6	216613400	*	*	*
R22CW1	216613400	*	*	*
R22CW2	216613400	*	*	*
R22CW4	216613400	*	*	*
R22CW5	216613400	*	*	*
UL1293ECW8	216416000	EC2 / Page 24	C23 / Page 28	SS1 / Page 29
UL1793ECW7	216583700	EC2 / Page 24	C23 / Page 28	SS1 / Page 29
UL2030ECW12	216569300	EC41 / Page 27	C5 / Page 28	SS8 / Page 30
UL2030ECW7	216418500	EC3 / Page 24	C1 / Page 28	SS8 / Page 30
UL2100ECW0	216417500	EC2 / Page 24	C2 / Page 28	SS1 / Page 29
UL2100ECW1	216569200	EC40 / Page 26	C6 / Page 28	SS1 / Page 29
UL2494ECW8	216619000	EC43 / Page 27	C6 / Page 28	SS5 / Page 29
UL4000ECW1	216418000	EC2 / Page 24	C2 / Page 28	SS7 / Page 30

* Information not available

BROICH SCHEMATIC INDEX LIST				
Model	Service Data Sheet	Electrical Diagram	Relay/Overload	System Schematic
UL4000ECW3	216619200	EC43 / Page 27	C6 / Page 28	SS6 / Page 30
UL5000ECW3	216619200	EC43 / Page 27	C6 / Page 28	SS6 / Page 30
XF22CW0	216618800	*	*	*
XR22CW0	216618800	*	*	*
EDINA TECH SCHEMATIC INDEX LIST				
FMR5	216497200	EC6 / Page 25	C9 / Page 28	SS4 / Page 29
FMW2	216510400	EC6 / Page 25	C9 / Page 28	SS4 / Page 29
FMW3	216510400	EC6 / Page 25	C9 / Page 28	SS4 / Page 29
TAPPAN SCHEMATIC INDEX LIST				
TFC05M4AW3	216372600	EC5 / Page 24	C9 / Page 28	SS3 / Page 29
TFC07M4CW2	216372600	EC5 / Page 24	C9 / Page 28	SS3 / Page 29
TFC09M4AW3	216372600	EC5 / Page 24	C9 / Page 28	SS3 / Page 29
VENEX INC. SCHEMATIC INDEX LIST				
ER142	216430900	EC14 / Page 25	C1 / Page 28	SS8 / Page 30
ER143	216430900	EC14 / Page 25	C1 / Page 28	SS8 / Page 30
ER145	216607700	EC14 / Page 25	C1 / Page 28	SS8 / Page 30
VV204	216418500	EC3 / Page 24	C1 / Page 28	SS8 / Page 30
VV205	216418500	EC3 / Page 24	C1 / Page 28	SS8 / Page 30
VV207	216560000	EC3 / Page 24	C1 / Page 28	SS8 / Page 30

* Information not available

ELECTRICAL CIRCUITS

EC1

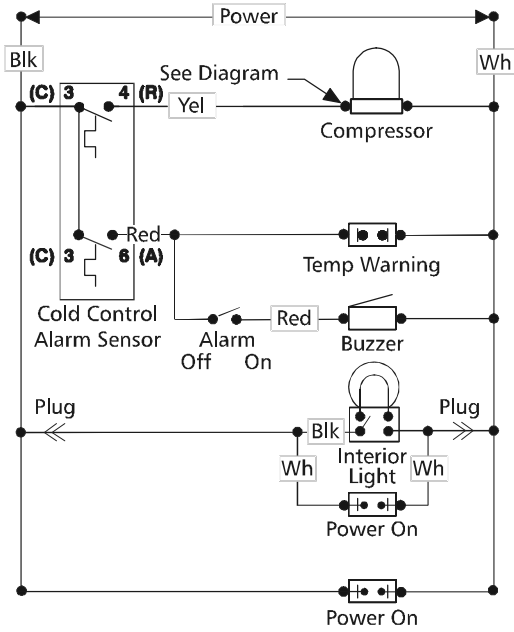

EC2

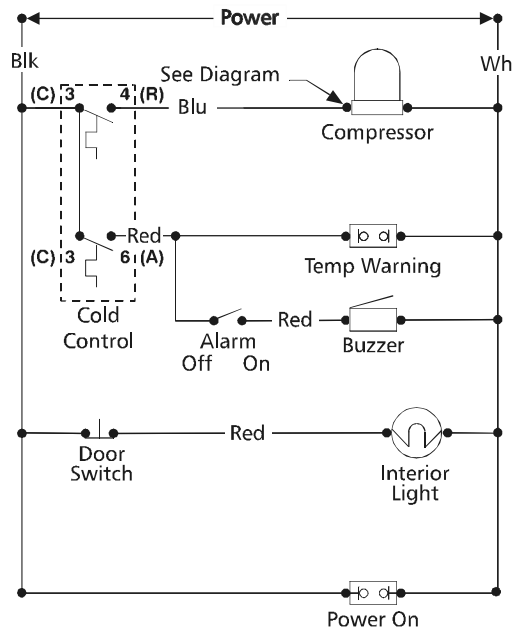

EC3

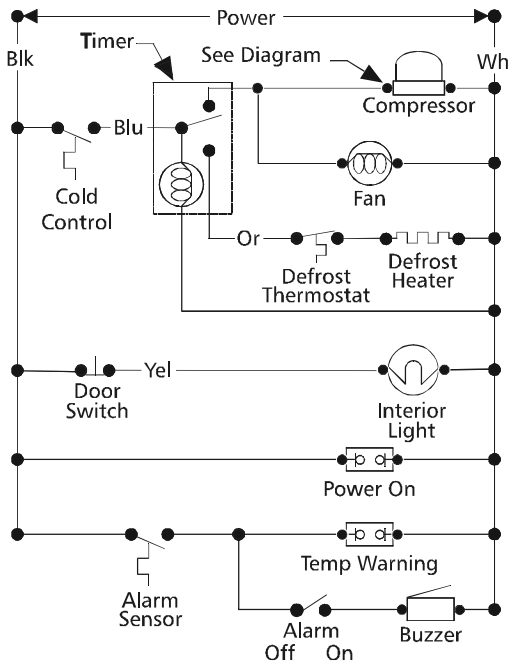

EC5

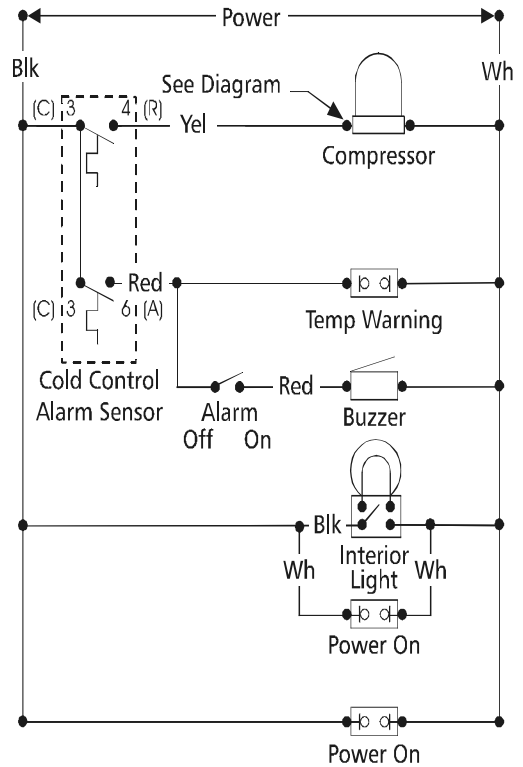

ELECTRICAL CIRCUITS

EC6

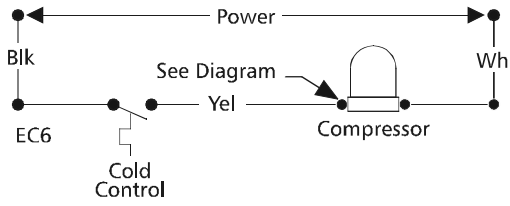

EC17

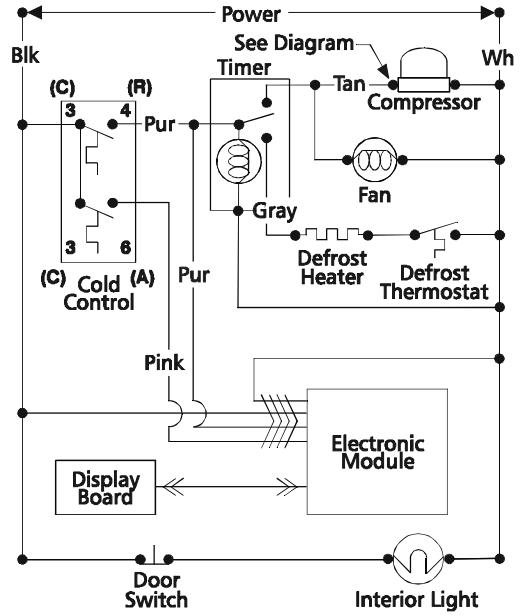

EC9

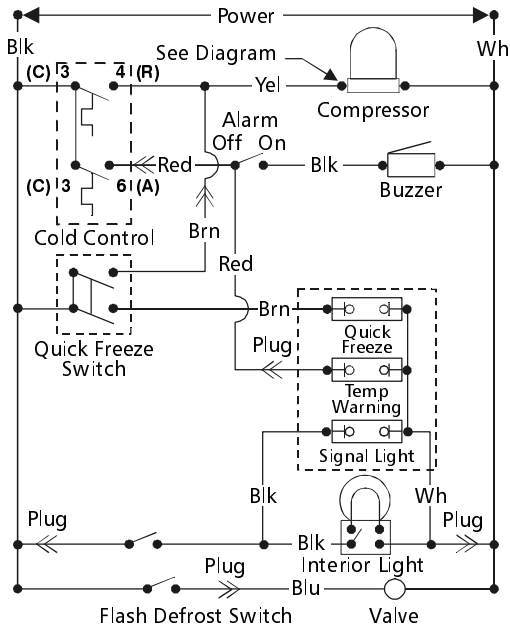

EC21

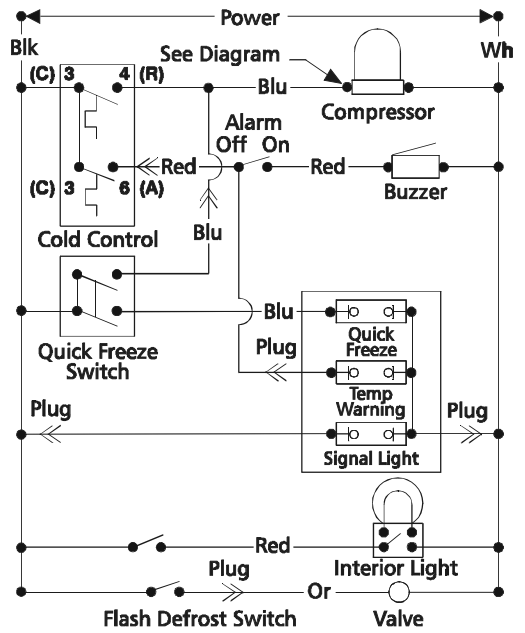

EC14

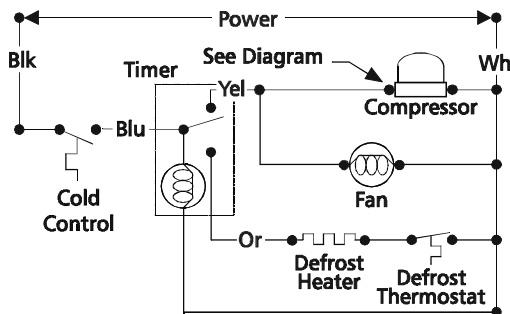

ELECTRICAL CIRCUITS

EC23

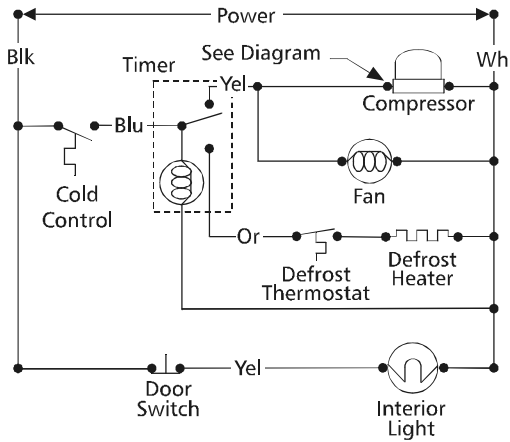

EC25

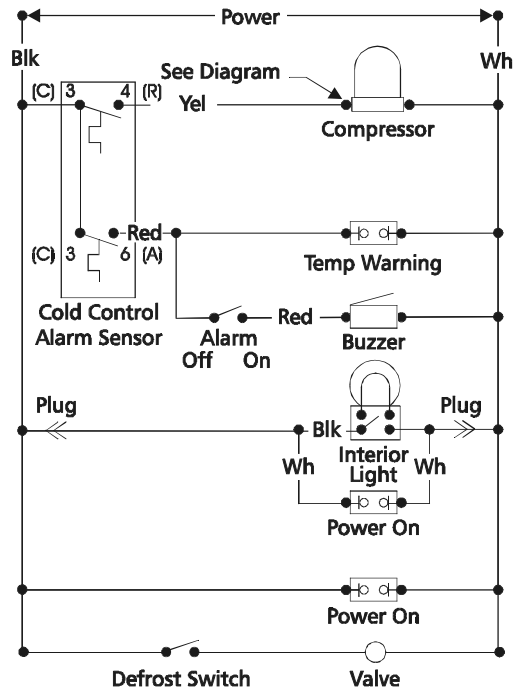

EC26

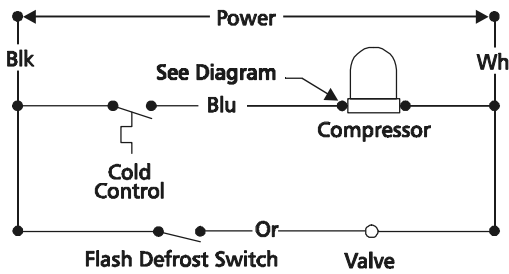

EC27

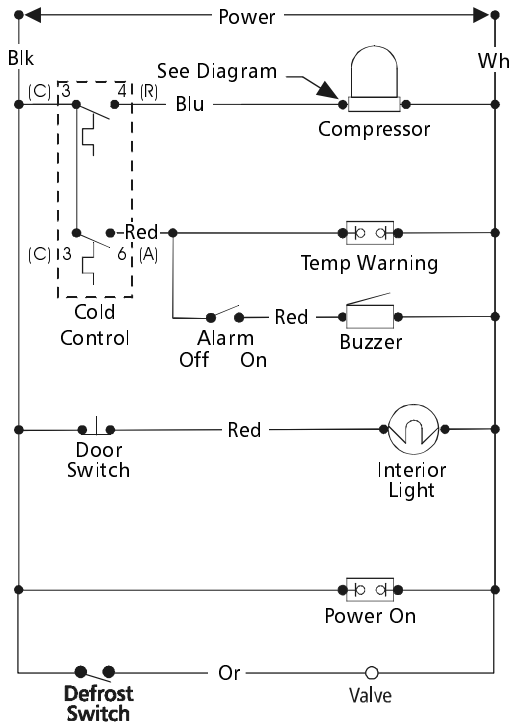

EC40

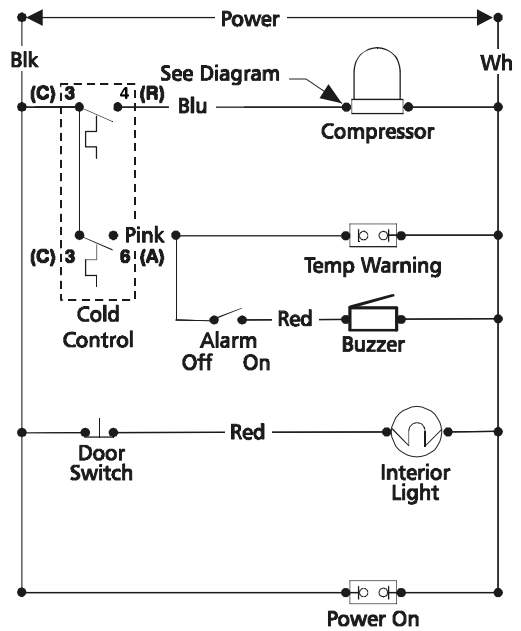

ELECTRICAL CIRCUITS

EC41

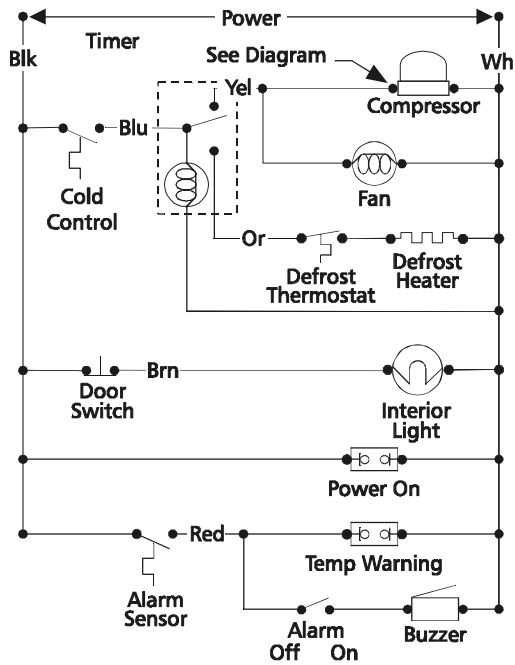

EC42

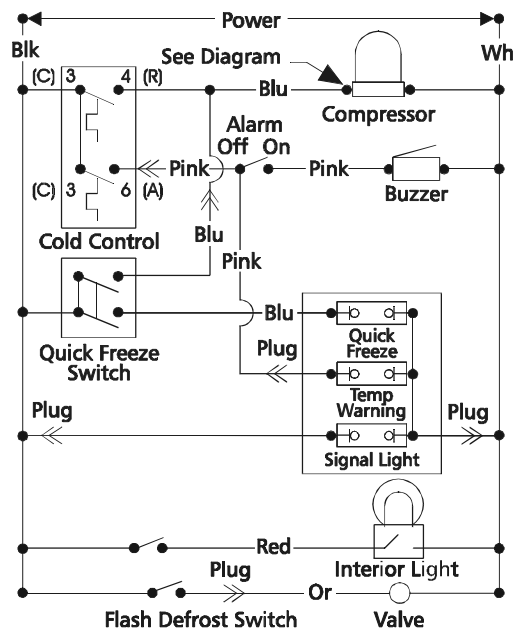

EC43

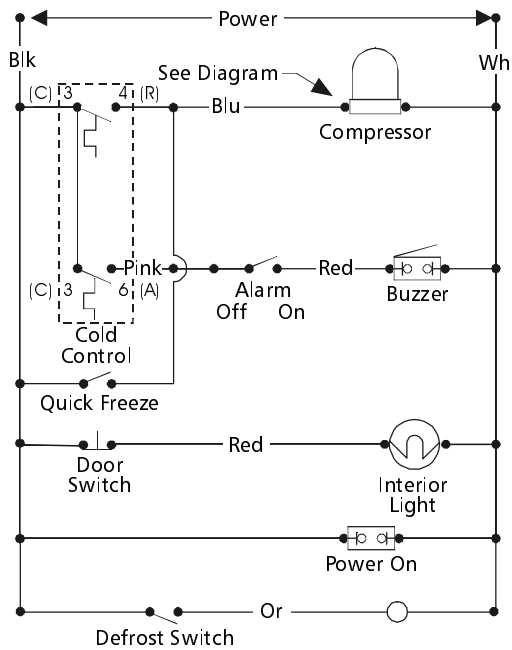

EC58

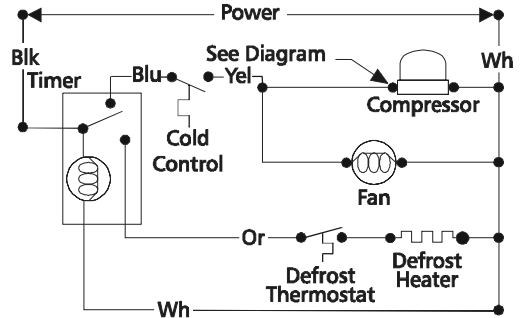

RELAY / OVERLOAD SCHEMATICS

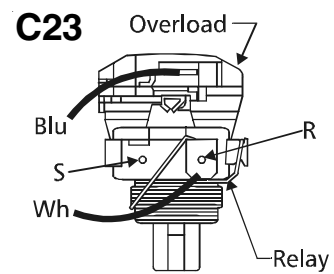
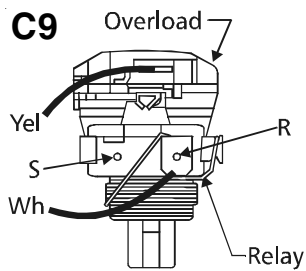
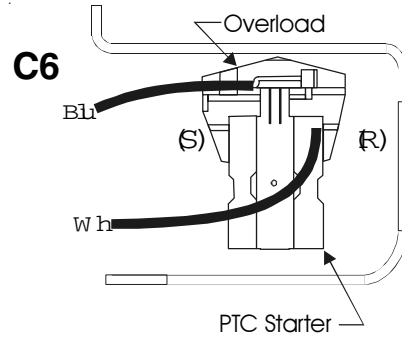
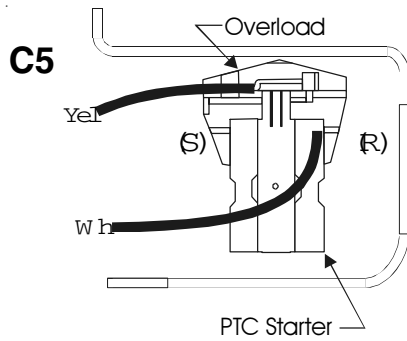
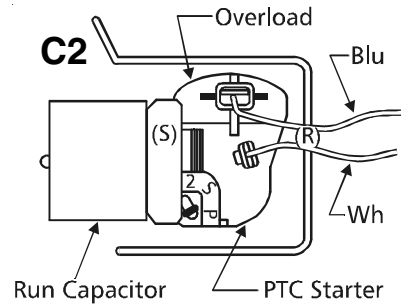
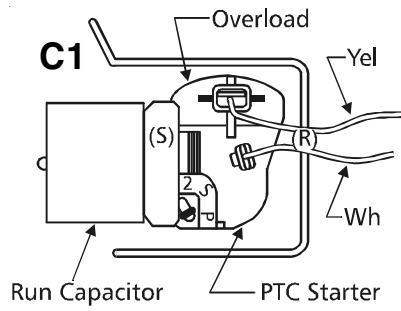

SYSTEM SCHEMATICS

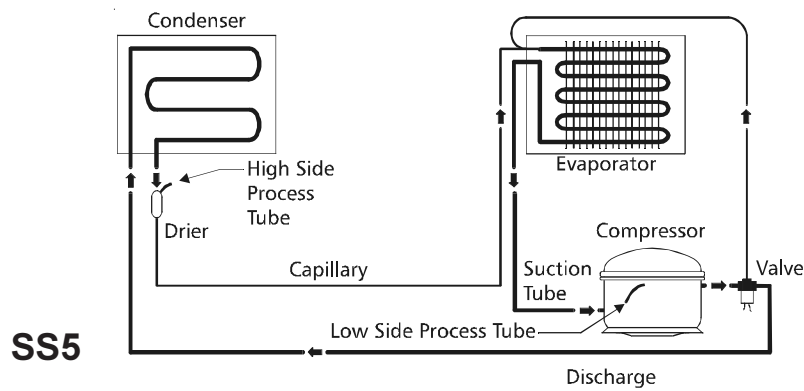
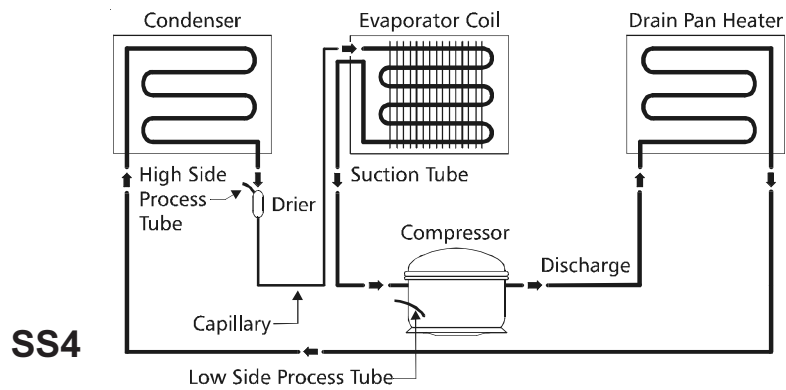
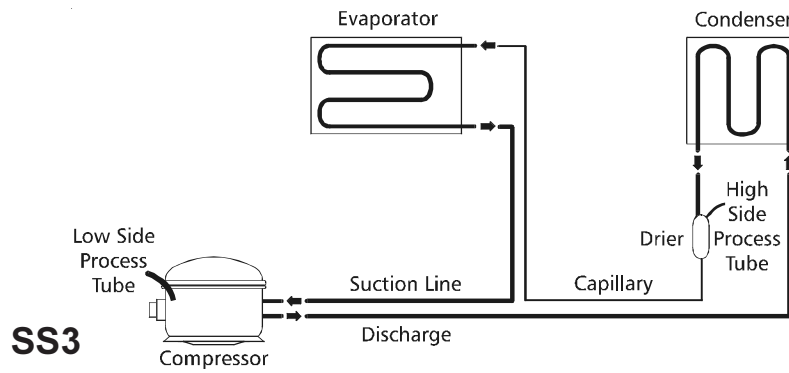
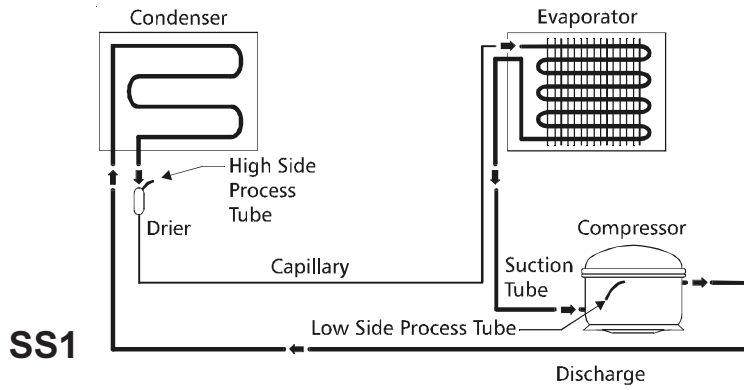

SYSTEM SCHEMATICS

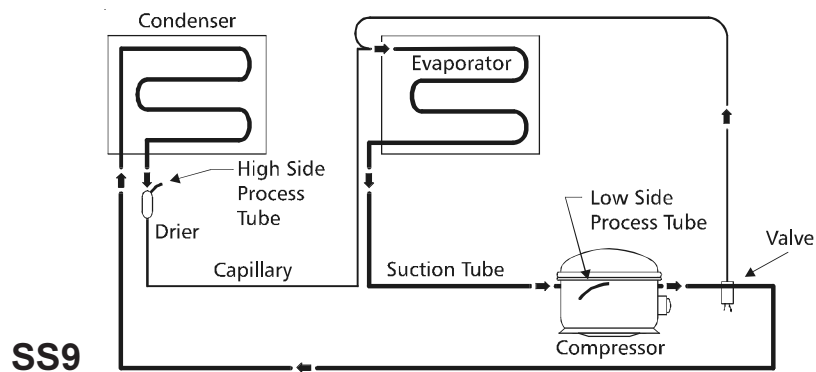
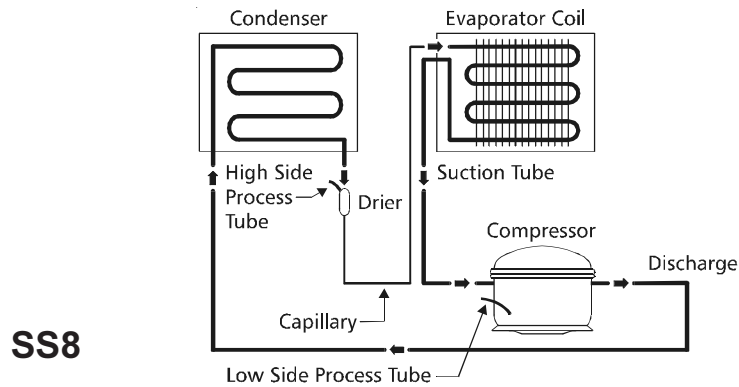
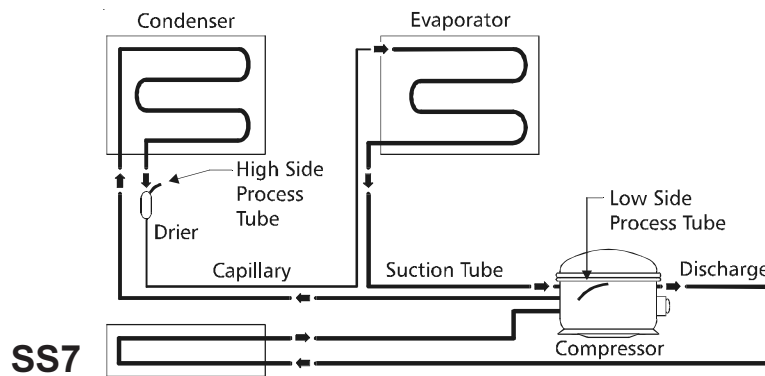
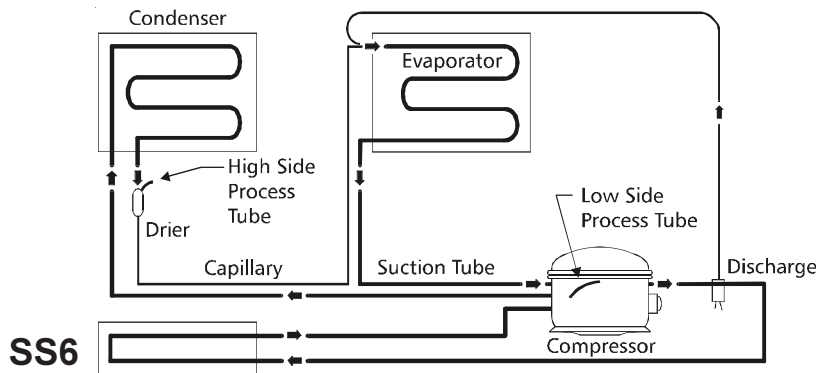

TROUBLESHOOTING GUIDE

PROBLEM	CAUSE	REMEDY
Compressor will not run.	No voltage at wall receptacle.	Check circuit breaker, fuse or Ground Fault Circuit Interruptors.
	Service cord defective, or unplugged at wall receptacle.	Check cord.
	Low voltage causing compressor to cycle on overload.	Voltage fluctuation should not exceed +/- 10% of 115VAC. (104 - 127 VAC)
	Control Thermostat knob in OFF position.	Turn Control Thermostat knob to the ON position.
	Inoperative Control Thermostat.	Replace Control Thermostat.
	Compressor stuck.	Replace compressor.
	Compressor windings open.	Replace compressor.
	Defrost Timer stuck in defrost mode. (Frost Free Models Only)	Replace Defrost Timer.
	Compressor overload stuck open.	Replace compressor overload.
	Relay lead loose.	Repair or replace lead.
	Relay loose or inoperative.	Replace relay.
	Service cord pulled out of harness.	Repair connection.
	Faulty cabinet wiring.	Repair wiring.
Compressor runs but no refrigeration.	System out of refrigerant.	Check for leaks.
	Compressor not pumping.	Replace compressor.
	Restricted Filter Drier.	Replace Filter Drier.
	Restricted capillary tube.	Replace heat exchanger and evaporator assembly on Upright freezers. On Chest freezers, contact the Customer Assistance Center for product replacement.
	Moisture in system.	Repair or replace component that is leaking. Replace the compressor if the system is contaminated. Blow out remaining part of system with Dry Nitrogen. Pump down and recharge.

PROBLEM	CAUSE	REMEDY
Compressor short cycles.	Erratic Control Thermostat.	Replace Control Thermostat.
	Faulty relay.	Replace relay.
	Restricted air flow over cabinet. (Condenser is in cabinet)	Leave a 3" space on all sides of the freezer for adequate circulation of air around freezer.
	Low voltage. Fluctuation exceeds +/- 10% of 115 VAC. (104-127 VAC)	Call a qualified electrician.
	Compressor draws excessive wattage.	Replace compressor.
Compressor runs too much.	Erratic Control Thermostat, or improperly set.	Replace Control Thermostat, or re-set to normal position.
	Freezer exposed to unusual heat.	Relocate freezer.
	High room temperature. (110° or higher)	Advise customer.
	Low pumping capacity compressor.	Replace compressor.
	Door gaskets not sealing.	Adjust or replace necessary parts.
	System undercharged.	Check for leaks.
	System overcharged.	Correct charge.
	Interior light stays on.	Check door switch.
	Non-condensables in system.	Flush out system. Replace filter drier, evacuate and recharge.
	Capillary tube kinked or partially restricted.	Replace heat exchanger and evaporator assembly on Upright freezers. On Chest freezers, contact the Customer Assistance Center for product replacement.
	Filter drier partially restricted.	Replace filter drier.
	Excessive service load.	Advise customer.
	Restricted air flow over cabinet. (Condenser is in cabinet)	Leave a 3" space on all sides of the freezer for adequate circulation of air around freezer.

PROBLEM	CAUSE	REMEDY
Noisy	Tubing vibrates.	Adjust tubing.
	Internal compressor noise.	Replace compressor.
	Loose parts.	Check shelving, kickplate, defrost drain pan.
	Compressor operating at high head pressure due to restricted air flow over cabinet. (Condenser is in cabinet)	Leave a 3" space on all sides of the freezer for adequate circulation of air around freezer.
	Inoperative evaporator fan motor. (Frost Free models only)	Check wiring and evaporator fan motor.
Freezer compartment too warm.	Improperly positioned fan.	Position fan 1/8" from leading edge of fan blade to freezer lines on Frost Free models. On manual defrost models, advise customer..
	Evaporator frosted up.	Check defrost system on Frost Free models. On manual defrost freezers, advise customer.
	Restricted air flow over cabinet. (Condenser is in cabinet)	Leave a 3" space around all sides of the freezer for adequate circulation of air around freezer.
	Excessive service load.	Advise customer.
	High room temperatures. (110° or higher)	Advise customer.
	Freezer compartment door left open.	Advise customer.
	Control Thermostat out of calibration.	Replace Control Thermostat.
	Door gasket not sealing.	Adjust or replace necessary parts.
	Control Thermostat capillary tube improperly positioned.	Reposition sensing element.
	Shortage of refrigerant.	Check for leaks.
	Restricted filter drier or capillary tube.	Check for leaks or burnt compressor windings.

PROBLEM	CAUSE	REMEDY
Automatic Defrost Models Only Evaporator blocked with ice.	Inoperative Defrost Timer.	Check wiring and Defrost Timer.
	Defrost Thermostat terminates too early.	Check for correct positioning of Defrost Thermostat or replace.
	Defrost Timer wired incorrectly.	Check wiring.
	Inoperative fan motor.	Check wiring and fan motor.
	Inoperative Defrost Thermostat.	Check wiring and Defrost Thermostat.
	Inoperative Defrost Heater.	Check wiring and Defrost Heater.
	Freezer door left open.	Advise customer.
	Freezer defrost drain plugged.	Clean drain port.



PO Box 212378 Augusta, GA 30917

