

This Base Manual covers 22, 24, and
26 Cu. Ft. Side by Side Refrigerators.
Refer to individual Technical Sheet
for specific information on models.

Service

22, 24, & 26 Cu. Ft. Side by Side Refrigerators

This manual is to be used by qualified appliance technicians only.
Amana does not assume any responsibility for property damage or
personal injury for improper service procedures done by an



RS1300005
Revision 0
November 2001

Important Information

Pride and workmanship go into every product to provide our customers with quality products. It is possible, however, that during its lifetime a product may require service. Products should be serviced only by a qualified service technician who is familiar with the safety procedures required in the repair and who is equipped with the proper tools, parts, testing instruments and the appropriate service manual. **REVIEW ALL SERVICE INFORMATION IN THE APPROPRIATE SERVICE MANUAL BEFORE BEGINNING REPAIRS.**

Important Notices for Consumers and Servicers

WARNING

To avoid risk of serious injury or death, repairs should not be attempted by unauthorized personnel, dangerous conditions (such as exposure to electrical shock) may result.

CAUTION

Amana will not be responsible for any injury or property damage from improper service procedures. If performing service on your own product, assume responsibility for any personal injury or property damage which may result.

To locate an authorized servicer, please consult your telephone book or the dealer from whom you purchased this product. For further assistance, please contact:

CONSUMER AFFAIRS DEPT.
AMANA APPLIANCES
AMANA, IOWA 52204

**OR
CALL**

1-319-622-5511 or (1-800-843-0304)
and ask for
Consumer Affairs

If outside the United States contact:

AMANA
ATTN: CONSUMER AFFAIRS DEPT.
AMANA, IOWA 52204, USA
Telephone: (319) 622-5511
Facsimile: (319) 622-2180
TELEX: 4330076 AMANA
CABLE: "AMANA", AMANA, IOWA, USA

Recognize Safety Symbols, Words, and Labels

DANGER

DANGER—Immediate hazards which **WILL** result in severe personal injury or death.

WARNING

WARNING—Hazards or unsafe practices which **COULD** result in severe personal injury or death.

CAUTION

CAUTION—Hazards or unsafe practices which **COULD** result in minor personal injury or product or property damage.

Table of Contents

Important Information.....	2	System Diagnosis.....	27
Product Design.....	4	Disassembly Procedures	
Component Testing.....	5	Refrigerator Compartment.....	30
Service Procedures.....	10	Upper Light Socket & Lens.....	30
Service Equipment.....	10	Freezer Cold Control.....	30
Drier Replacement.....	10	Defrost Timer.....	30
Refrigerant Precautions.....	11	Adaptive Defrost Control.....	30
Line Piercing Valves.....	11	Damper Control.....	31
Open Lines.....	11	Water Filter Assembly.....	31
Compressor Operational Test.....	11	Water Tank Assembly.....	31
Dehydrating Sealed Refrigeration System.....	12	Crisper Cover and Socket.....	31
Leak Testing.....	12	Freezer Compartment	
Testing Systems Containing a		Freezer Light Socket.....	31
Refrigerant Charge.....	12	Auger Motor Assembly.....	31
Testing Systems Containing		Auger Motor.....	31
No Refrigerant Charge.....	12	Auger Motor Capacitor.....	32
Restrictions.....	13	Evaporator Fan Motor Assembly.....	32
Symptoms.....	13	Evaporator Fan Motor and Fan Blade.....	32
Testing for Restrictions.....	13	Evaporator Removal.....	32
Evacuation and Charging.....	14	Defrost Terminator (Thermostat).....	32
Evacuation.....	14	Defrost Heater.....	32
Charging.....	15	Ice Maker Removal.....	33
Refrigerant Charge.....	15	Machine Compartment	
HFC134a Service Information.....	16	Water Valves.....	33
Health, Safety, and Handling.....	16	Condenser Fan motor and Blade.....	33
Comparison of CFC12 and HFC134a Properties..	16	Compressor.....	33
Replacement Service Compressor.....	17	Condensate Drain Tube.....	33
Compressor Testing Procedures.....	17	Condensate Drain Pan.....	33
Brazing.....	17	Overload/Relay.....	34
Refrigerant Flow 22, 24, 26 cu. ft.....	18	Condenser.....	34
Cabinet Air Flow 24, 26 cu. ft.....	19	Bottom of Cabinet	
Cabinet Air Flow 22 cu. ft.....	20	Front Leveling Rollers.....	34
Ice and Water Dispenser Diagram.....	21	Rear Leveling Rollers.....	34
Water Valves Diagram.....	22	Cabinet Doors	
Typical External Sweat Pattern.....	23	Door Gaskets.....	34
Troubleshooting Chart.....	24	Dispenser Facade (Messenger Model).....	34
		Dispenser Ice Chute Door.....	35
		Dispenser Light Socket.....	35
		Dispenser D/C Solenoid.....	35
		Dispenser Water Tube.....	35
		High Voltage Board (Messenger Model).....	35
		Ice 'N Water Systems	
		Troubleshooting of 5 button Dispenser.....	36
		Troubleshooting of Messenger Dispenser.....	40
		Troubleshooting of 3 button Dispenser.....	45
		Appendix A	
		Owner's Manual.....	A-2

Product Design



WARNING

To avoid risk of electrical shock, personal injury, or death, disconnect electrical power source to unit, unless test procedures require power to be connected. Discharge capacitor through a resistor before attempting to service. Ensure all ground wires are connected before certifying unit as repaired and/or operational.

Refrigeration System

Compressor forces high temperature vapor into fan cooled tube and wire condenser where vapor is cooled and condensed into high pressure liquid by circulation of air across condenser coil. (See Refrigerant Flow Diagram, page 18)

High pressure liquid passes into post-condenser loop which helps to prevent condensation around freezer compartment opening and through molecular sieve drier and into capillary tube. Small inside diameter of capillary offers resistance, decreasing pressure, and temperature of liquid discharged into evaporator. Capillary diameter and length is carefully sized for each system.

Capillary enters evaporator at top back. Combined liquid and saturated gas flows through back to bottom of coil and into suction line. Aluminium tube evaporator coil is located in freezer compartment where circulating evaporator fan moves air through coil and into fresh food compartment.

Large surface of evaporator allows heat to be absorbed from both fresh food and freezer compartments by airflow over evaporator coil causing some of the liquid to evaporate. Temperature of evaporator tubing near end of running cycle may vary from -13° to -25°F.

Saturated gas is drawn off through suction line where superheated gas enters compressor. To raise temperature of gas, suction line is placed in heat exchange with capillary.

Temperature Controls

Freezer compartment temperature is regulated by air sensing thermostat at rear back of fresh food compartment which actuates compressor. Control capillary is inserted in well which routes capillary into freezer. Control should be set to maintain freezer temperature between 0° to -2°F.

Fresh food compartment temperature is regulated an air damper control governing amount of refrigerated air entering fresh food compartment from freezer. Fresh food compartment temperature should be between 38° and 40°F.

Defrost Timer System (some models)

Every 8 hours of compressor run time defrost timer activates radiant electric defrost heater suspended from evaporator. After 33 minutes of defrost cycle time, timer restores circuit to compressor.

Defrost terminator (thermostat) is wired in series with defrost heater. Terminator opens and breaks circuit when preset high temperature is reached. After defrost thermostat opens, thermostat remains open until end of defrost cycle when cooling cycle starts and terminator senses present low temperature and closes.

Defrost heater is suspended on left side of evaporator coil and across bottom to keep defrost drain free flowing during defrost. Defrost water is caught in trough under evaporator coil and flows through drain hole in liner and drain tubing into drain pan. Air circulated by condenser fan over pan evaporates water.

Adaptive Defrost System (some models)

The ADC adapts the compressor run time between defrosts to achieve optimum defrost intervals by monitoring the cold control and length the defrost heater is on.

Component Testing



WARNING

To avoid risk of electrical shock, personal injury, or death, disconnect electrical power source to unit, unless test procedures require power to be connected. Discharge capacitor through a resistor before attempting to service. Ensure all ground wires are connected before certifying unit as repaired and/or operational.

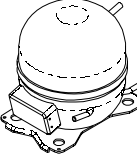

Component	Description	Test Procedures
 <p>Compressor</p>	<p>When compressor electrical circuit is energized, the start winding current causes relay to heat. After an amount of starting time, the start winding circuit turns off. The relay will switch off the start winding circuit even though compressor has not started (for example, when attempting to restart after momentary power interruption).</p> <p>With "open" relay, compressor will not start because there is little or no current to start windings. Overload protection will open due to high locked rotor run winding current.</p> <p>With "shorted" relay or capacitor, compressor will start and overload protector will quickly open due to high current of combined run and start windings.</p> <p>With open or weak capacitor, compressor will start and run as normal but will consume more energy.</p>	<p>Resistance test</p> <ol style="list-style-type: none"> 1. Disconnect power to unit. 2. Discharge capacitor by shorting across terminals with a resistor for 1 minute. <p>NOTE: (Some compressors do not have a run capacitor.)</p> <ol style="list-style-type: none"> 3. Remove leads from compressor terminals. 4. Set ohmmeter to lowest scale. 5. Check for resistance between <ul style="list-style-type: none"> Terminals "S" and "C", start winding Terminals "R" and "C", run winding If either compressor winding reads open (infinite or very high resistance) or dead short (0 ohms), replace compressor. <p>Ground test</p> <ol style="list-style-type: none"> 1. Disconnect power to refrigerator. 2. Discharge capacitor, if present, by shorting terminals through a resistor. 3. Remove compressor leads and use an ohmmeter set on highest scale. 4. Touch one lead to compressor body (clean point of contact) and other probe to each compressor terminal. <ul style="list-style-type: none"> • If reading is obtained, compressor is grounded and must be replaced. <p>Operation test</p> <p>If voltage, capacitor, overload, and motor winding tests do not show cause for failure, perform the following test:</p> <ol style="list-style-type: none"> 1. Disconnect power to refrigerator. 2. Discharge capacitor by shorting capacitor terminals through a resistor. 3. Remove leads from compressor terminals. 4. Wire a test cord to power switch. 5. Place time delayed fuse with UL rating equal to amp rating of motor in test cord socket. (Refer to Technical Data Sheet) 6. Remove overload and relay. 7. Connect start, common and run leads of test cord on appropriate terminals of compressor. 8. Attach capacitor leads of test cord together. If capacitor is used, attach capacitor lead to a known good capacitor of same capacity. <div data-bbox="971 1213 1300 1560" style="text-align: center;"> <p>The diagram illustrates the test configuration. It shows an AC supply connected to a switch. The circuit then passes through fuses. The wires from the fuses connect to the start (S), common (C), and run (R) terminals of a compressor. A capacitor is connected across the start (S) and run (R) terminals.</p> </div> <p style="text-align: center;">Test configuration</p> <ol style="list-style-type: none"> 9. Plug test cord into multimeter to determine start and run wattage and to check for low voltage, which can also be a source of trouble indications. 10. With power to multimeter, press start cord switch and release. <ul style="list-style-type: none"> • If compressor motor starts and draws normal wattage, compressor is okay and trouble is in capacitor, relay/overload, freezer temperature control, or elsewhere in system. • If compressor does not start when direct wired, recover refrigerant at high side. After refrigerant is recovered, repeat compressor direct wire test. If compressor runs after recovery but would not run when direct wired before recover, a restriction in sealed system is indicated. • If compressor does not run when wired direct after recovery, replace faulty compressor.

Component Testing

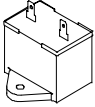

WARNING

To avoid risk of electrical shock, personal injury, or death, disconnect electrical power source to unit, unless test procedures require power to be connected. Discharge capacitor through a resistor before attempting to service. Ensure all ground wires are connected before certifying unit as repaired and/or operational.



Component	Description	Test Procedures
<p>Capacitor</p> 	<p>Run capacitor connects to relay terminal 3 and L side of line.</p> <p>Some compressors do not require a run capacitor; refer to the Technical Data Sheet for the unit being serviced.</p>	<div style="border: 1px solid black; padding: 5px; margin-bottom: 10px;">  <h3 style="margin: 0;">WARNING</h3> <p>To avoid electrical shock which can cause severe personal injury or death, discharge capacitor through a resistor before handling.</p> </div> <ol style="list-style-type: none"> 1. Disconnect power to refrigerator. 2. Remove capacitor cover and disconnect capacitor wires. 3. Discharge capacitor by shorting across terminals with a resistor for 1 minute. 4. Check resistance across capacitor terminals with ohmmeter set on "X1K" scale. <ul style="list-style-type: none"> • Good—needle swings to 0 ohms and slowly moves back to infinity. • Open—needle does not move. Replace capacitor. • Shorted—needle moves to zero and stays. Replace capacitor. • High resistance leak—needle jumps toward 0 and then moves back to constant high resistance (not infinity).
<p>Condenser</p>	<p>Condenser is a tube and wire construction located in machine compartment.</p> <p>Condenser is on high pressure discharge side of compressor. Condenser function is to transfer heat absorbed by refrigerant to ambient.</p> <p>Higher pressure gas is routed to condenser where, as gas temperature is reduced, gas condenses into a high pressure liquid state. Heat transfer takes place because discharged gas is at a higher temperature than air that is passing over condenser. It is very important that adequate air flow over condenser is maintained.</p> <p>Condenser is air cooled by condenser fan motor. If efficiency of heat transfer from condenser to surrounding air is impaired, condensing temperature becomes higher. High liquid temperature means liquid will not remove as much heat during boiling in evaporator as under normal conditions. This would be indicated by high than normal head pressures, long run time, and high wattage. Remove any lint or other accumulation, that would restrict normal air movement through condenser.</p> <p>From condenser the refrigerant flows into a post condenser loop which helps control exterior condensation on flange, center mullion, and around freezer door. Refrigerant the flows through the drier to evaporator and into compressor through suction line.</p>	<p>Leaks in condenser can usually be detected by using an electronic leak detector or soap solution. Look for signs of compressor oil when checking for leaks. A certain amount of compressor oil is circulated with refrigerant.</p> <p>Leaks in post condenser loop are rare because loop is a one-piece copper tube.</p> <p>For minute leaks</p> <ol style="list-style-type: none"> 1. Separate condenser from rest of refrigeration system and pressurize condenser up to a maximum of 235 PSI with a refrigerant and dry nitrogen combination. 2. Recheck for leaks. <div style="border: 1px solid black; padding: 5px; margin-top: 10px;">  <h3 style="margin: 0;">WARNING</h3> <p>To avoid severe personal injury or death from sudden eruption of high pressures gases, observe the following: Protect against a sudden eruption if high pressures are required for leak checking. Do not use high pressure compressed gases in refrigeration systems without a reliable pressure regulator and pressure relief valve in the lines.</p> </div>

Component Testing

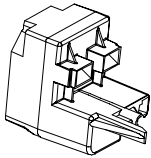
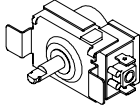
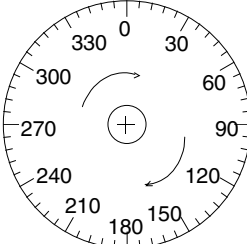

WARNING

To avoid risk of electrical shock, personal injury, or death, disconnect electrical power source to unit, unless test procedures require power to be connected. Discharge capacitor through a resistor before attempting to service. Ensure all ground wires are connected before certifying unit as repaired and/or operational.

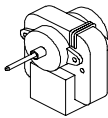



Component	Description	Test Procedures														
 <p>Overload / Relay</p>	<p>When voltage is connected and relay is cool, current passes through relay to start winding.</p> <p>After a short time, current heats the resistor in relay and resistance will rise blocking current flow through relay.</p> <p>Start winding remains in the circuit through run capacitor.</p> <p>Solid state relay plugs directly on compressor start and run terminals. Relay terminals 2 and 3 are connected within relay. Run capacitor is connected to relay terminal 3. L2 side of 120 VAC power is connected to relay terminal 2.</p>	<ol style="list-style-type: none"> 1. Disconnect power to the refrigerator. 2. Remove relay cover and disconnect leads. 3. Check resistance across terminals 2 and 3 with an ohmmeter: Normal = 3 to 12 ohms Shorted = 0 ohms Open = infinite ohms 														
 <p>Freezer temperature control</p>	<p>Freezer temperature control is a capillary tube operating a single pole, single throw switch.</p> <p>Freezer temperature control controls run cycle through defrost timer.</p> <p>Altitude Adjustment When altitude adjustment is required on a G.E. control, turn altitude adjustment screw 1/7 turn counter clockwise for each 1,000 feet increase in altitude up to 10,000 feet. One full turn equals 10,000 feet maximum.</p> <p>In most cases the need for altitude adjustments can be avoided by simply turning temperature control knob to colder setting.</p>	<p>Check for proper calibration with thermocouple capillary in air supply well by recording cut-in and cut-out temperatures at middle setting. Refer to tech sheet for model being serviced for expected temperatures.</p> <p>Check control contacts are opening by disconnecting electrical leads to control and turning control knob to coldest setting. Check for continuity across terminals.</p> <table border="1" data-bbox="760 1018 1112 1291"> <thead> <tr> <th colspan="2">Altitude Counter in Feet</th> </tr> <tr> <th>Feet Above Sea Level</th> <th>Turn Screw Clockwise (Angular Degrees)</th> </tr> </thead> <tbody> <tr> <td>2,000</td> <td>30</td> </tr> <tr> <td>4,000</td> <td>81</td> </tr> <tr> <td>6,000</td> <td>129</td> </tr> <tr> <td>8,000</td> <td>174</td> </tr> <tr> <td>10,000</td> <td>216</td> </tr> </tbody> </table> 	Altitude Counter in Feet		Feet Above Sea Level	Turn Screw Clockwise (Angular Degrees)	2,000	30	4,000	81	6,000	129	8,000	174	10,000	216
Altitude Counter in Feet																
Feet Above Sea Level	Turn Screw Clockwise (Angular Degrees)															
2,000	30															
4,000	81															
6,000	129															
8,000	174															
10,000	216															
<p>Ice Maker</p>	<p>Optional on some models.</p> <p>See "Ice Maker" section for service information.</p>															
 <p>ECM condenser motor</p>	<p>Condenser fan moves cooling air across condenser coil and compressor body.</p> <p>Condenser fan motor is in parallel circuit with compressor.</p>	<p>Check resistance across coil.</p>														
 <p>Evaporator fan motor</p>	<p>Evaporator fan moves air across evaporator coil and throughout refrigerator cabinet.</p>	<ol style="list-style-type: none"> 1. Disconnect power to unit. 2. Disconnect fan motor leads. 3. Check resistance from ground connection solder. Trace to motor frame must not exceed .05 ohms. 4. Check for voltage at connector to motor with unit in refrigeration mode and compressor operating. 														

Component Testing

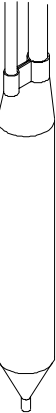

WARNING

To avoid risk of electrical shock, personal injury, or death, disconnect electrical power source to unit, unless test procedures require power to be connected. Discharge capacitor through a resistor before attempting to service. Ensure all ground wires are connected before certifying unit as repaired and/or operational.

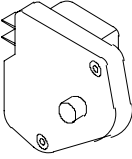
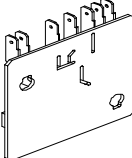
Component	Description	Test Procedures
 Refrigerator light switch	Single pole, single throw switch completes circuit for light when door is open.	Check resistant across terminals. Switch arm depressed "NO" terminals Open Switch arm up "NO" terminals Closed
 Freezer light / Interlock switch	Single pole, Double throw switch completes circuit for light when door is open. Completes circuit for dispenser when door is closed	Check resistant across terminals. Switch arm depressed "NO" terminals Open "NC" terminals Closed Switch arm not depressed "NC" terminals Open "NO" terminals Closed
 Drier	Drier is placed at post condenser loop outlet and passes liquefied refrigerant to capillary. Desiccant (20) 8 x 12 4AXH - 7 M>S> - Grams	<p>Drier must be changed every time the system is opened for testing or compressor replacement.</p> <p>NOTE: Drier used in R12 sealed system is not interchangeable with drier used in R134a sealed system. Always replace drier in R134a system with Amana part number B2150504.</p> <p>Before opening refrigeration system, recover HFC134a refrigerant for safe disposal.</p> <ol style="list-style-type: none"> Cut drier out of system using the following procedure. Do not unbraid drier. Applying heat to remove drier will drive moisture into the system. Score capillary tube close to drier and break. Reform inlet tube to drier allowing enough space for large tube cutter. Cut circumference of drier 1/4" below condenser inlet tube joint to drier. Remove drier. Apply heat trap paste on post condenser tubes to protect grommets from high heat. Unbraid remaining part of drier. Remove drier from system. Discard drier in safe place. Do not leave drier with customer. If refrigerator is under warranty, old drier must accompany warranty claim.
 <h2>WARNING</h2> <p>To avoid death or severe personal injury, cut drier at correct location. Cutting drier at incorrect location will allow desiccant beads to scatter. If spilled, completely clean area of beads.</p>		
 Defrost timer	Timer motor operates only when freezer control is closed. After specified amount of actual operating time, inner cam in timer throws the contacts from terminal 4, compressor circuit, to terminal 2, defrost thermostat/defrost heater circuit. After specified defrost cycle time, timer cam resets the circuitry through terminal 4 to compressor.	<ol style="list-style-type: none"> To check timer motor winding, check for continuity between terminals 1 and 3 of timer. Depending on rotating position of the cam, terminal 1 of timer is common to both terminal 2, the defrost mode, and terminal 4, the compressor mode. There should never be continuity between terminals 2 and 4. With continuity between terminals 1 and 4, rotate timer knob clockwise until audible click is heard. When the click is heard, reading between terminals 1 and 4 should be infinite and there should be continuity between terminals 1 and 2. Continuing to rotate time knob until a second click is heard should restore circuit between terminals 1 and 4.
 Adaptive defrost control (ADC)	The ADC adapts the compressor run time between defrosts to achieve optimum defrost intervals by monitoring the cold control and length the defrost heater is on.	Refer to specific Technical Data Sheet with unit for troubleshooting procedure.

Component Testing



WARNING

To avoid risk of electrical shock, personal injury, or death, disconnect electrical power source to unit, unless test procedures require power to be connected. Discharge capacitor through a resistor before attempting to service. Ensure all ground wires are connected before certifying unit as repaired and/or operational.

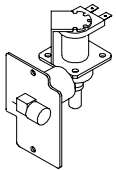
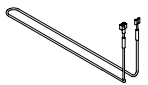
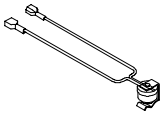
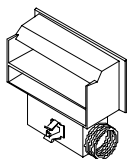
	Description	Test Procedures
 <p>Water valve</p>	<p>Controls water flow to the ice maker.</p> <p>Controlled by thermostat in ice maker.</p> <p>See Ice Maker Section for further information.</p>	<p>Check resistance across coil windings.</p>
<p>Evaporator</p>	<p>Inner volume of evaporator allows liquid refrigerant discharged from capillary to expand into refrigerant gas.</p> <p>Expansion cools evaporator tube and fin temperature to approximately -20°F transferring heat from freezer section to refrigerant.</p> <p>Passing through suction line to compressor, the refrigerant picks up superheat (a relationship between pressure and temperature that assures complete vaporization of liquid refrigerant) as the result of capillary tube soldered to suction line.</p> <p>Refrigerant gas is pulled through suction line by compressor, completing refrigeration cycle.</p>	<p>Test for leaks in evaporator with electronic leak detector or with soap solution. Compressor oil is circulated with refrigerant; check for oil when checking for leaks.</p> <p>For minute leaks</p> <ol style="list-style-type: none"> 1. Separate evaporator from rest of refrigeration system and pressurize evaporator up to a maximum of 140 PSI with a refrigerant and dry nitrogen combination. 2. Recheck for leaks.
 <p>Evaporator defrost heater</p>	<p>Activated when defrost thermostat, defrost timer, and freezer control complete circuit through heater.</p>	<p>Check resistance across heater.</p> <p>To check defrost system :</p> <ol style="list-style-type: none"> 1. Thermocouple defrost thermostat and plug refrigerator into wattmeter. 2. Turn into defrost mode. Wattmeter should read specified watts (according to Technical Data Sheet). 3. When defrost thermostat reaches specified temperature $\pm 5^\circ\text{F}$ (see Technical Data Sheet), thermostat should interrupt power to heater.
 <p>Thermostat</p>	<p>Thermostat is in a series circuit with terminal 2 of defrost timer, and defrost heater. Circuit is complete if evaporator fan motor operates when cold.</p> <p>Controls the circuit from freezer thermostat through defrost terminator to defrost heater. Opens and breaks circuit when thermostat senses preset high temperature.</p>	<p>Test continuity across terminals.</p> <p>With power off and evaporator coil below freezing, thermostat should show continuity when checked with ohmmeter. See "Heater, evaporator (defrost)" section for additional tests.</p> <p>After defrost thermostat opens, thermostat remains open until end of defrost cycle and refrigerator starts cooling again. Defrost thermostat senses a preset low temperature and resets (closes).</p>
 <p>Damper Control</p>	<p>Damper control balances the air delivery between refrigerator and freezer compartments providing temperature control for refrigerator.</p> <p>Internal capillary activates damper control and door closes restricting flow of air from freezer compartment to refrigerator compartment.</p>	<p>Subject capillary to appropriate temperature (refer to Technical Data Sheet for model being serviced).</p> <p>Damper door should close to within ¼" of completely shut.</p> <p>If altitude adjustment is required, turn altitude adjustment screw 1/8 turn clockwise for each 1,000 feet increase in altitude.</p> <p>There are no electrical connections to damper control. See Technical Data Sheet for damper specifications for unit being serviced.</p>



WARNING

To avoid severe personal injury or death from sudden eruption of high pressures gases, observe the following:

- Protect against a sudden eruption if high pressures are required for leak checking.
- Do not use high pressure compressed gases in refrigeration systems without a reliable pressure regulator and pressure relief valve in the lines.

Service Procedures



WARNING

To avoid risk of electrical shock, personal injury, or death, disconnect electrical power source to unit, unless test procedures require power to be connected. Discharge capacitor through a 10,000 ohm resistor before attempting to service. Ensure all ground wires are connected before certifying unit as repaired and/or operational.

Service Equipment

Listed below is equipment needed for proper servicing of HFC134a systems. Verify equipment is confirmed by manufacturer as being compatible with HFC134a and ester oil system.

Equipment must be exclusively used for HFC134a. Exclusive use of equipment only applies to italic items.

- **Evacuation pump**

Check with vacuum pump supplier to verify equipment is compatible for HFC134a. Robinair, Model 15600 2 stage, 6 cubic feet per minute pump is recommended.

- ***Four-way manifold gauge set, with low loss hoses***

- **Leak detector**

- ***Charging cylinder***

- ***Line piercing saddle valve***

(Schroeder valves). Seals must be HFC134a and ester oil compatible. Line piercing valves may be used for diagnosis but are not suitable for evacuation or charging, due to minute holes pierced in tubing. Do not leave mechanical access valves on system.

Valves eventually will leak. Molecules of HFC134a are smaller than other refrigerants and will leak where other refrigerants would not.

- ***Swagging tools***

- ***Flaring tools***

- ***Tubing cutter***

- **Flux**

- **Sil-Fos**

- **Silver solder**

- ***Oil for swagging and flaring***

Use only part # R0157532

- ***Copper tubing***

Use only part # R0174075 and # R0174076

- **Dry nitrogen**

99.5% minimum purity, with -40°F or lower dew point

- **Crimp tool**

- **Tube bender**

- **Micron vacuum gauge**

- ***Process tube adaptor kit***

- **Heat trap paste**

- ***ICI appliance grade HFC134a***

Drier Replacement

Before opening refrigeration system, recover HFC134a refrigerant for safe disposal.

Every time sealed HFC134a system is repaired, drier filter must be replaced with, part # B2150504.

Cut drier out of system by completing the following steps. Do not unbrazed drier filter. Applying heat to remove drier will drive moisture into system.



WARNING

To avoid risk of severe personal injury or death, cut drier at correct location. Cutting drier at incorrect location will allow desiccant beads to scatter. Completely clean area of beads, if spilled.

1. Score capillary tube close to drier and break.
2. Reform inlet tube to drier allowing enough space for large tube cutter.
3. Cut circumference of drier at 1-1/4", below condenser inlet tube joint to drier.
4. Remove drier.
5. Apply heat trap paste on post condenser tubes to protect grommets from high heat.
6. Unbrazed remaining part of drier. Remove drier from system.
7. Discard drier in safe place. Do not leave drier with customer. If refrigerator is under warranty, old drier must accompany warranty claim.

Service Procedures



WARNING

To avoid risk of electrical shock, personal injury, or death, disconnect electrical power source to unit, unless test procedures require power to be connected. Discharge capacitor through a 10,000 ohm resistor before attempting to service. Ensure all ground wires are connected before certifying unit as repaired and/or operational.

Refrigerant Precautions



WARNING

To avoid risk of personal injury, do not allow refrigerant to contact eyes or skin.



CAUTION

To avoid risk of property damage, do not use refrigerant other than that shown on unit serial number identification plate.

NOTE: All precautionary measures recommended by refrigerant manufacturers and suppliers apply and should be observed.

Line Piercing Valves

Line piercing valves can be used for diagnosis, but are not suitable for evacuating or charging due to holes pierced in tubing by valves.

NOTE: Do not leave line piercing valves on system. Connection between valve and tubing is not hermetically sealed. Leaks will occur.

Open Lines

During any processing of refrigeration system, never leave lines open to atmosphere. Open lines allow water vapor to enter system, making proper evacuation more difficult.

Compressor Operational Test

(short term testing only)

If compressor voltage, capacitor, overload, and motor winding tests are successful (do not indicate a fault), perform the following test:

1. Disconnect power to unit.
 2. Discharge capacitor by shorting capacitor terminals through a resistor.
- NOTE:** Not all units have run capacitor.
3. Remove leads from compressor terminals.
 4. Attach test cord to compressor windings.

- Common lead on test cord attaches to C terminal on compressor.
- Start lead on test cord attaches to S terminal on compressor.
- Run lead on test cord attaches to M terminal on compressor.

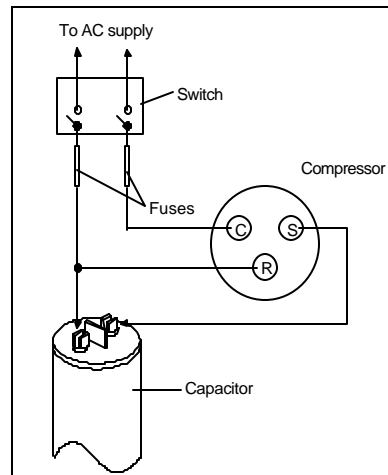

Attaching Capacitor for Compressor Test

5. Connect a known good capacitor into circuit as shown above. For proper capacitor size and rating, see technical data sheet for unit under test.

NOTE: Ensure test cord cables and fuses meet specifications for unit under test (see Technical Sheet for unit under test).

6. Replace compressor protector cover securely.
7. Plug test cord into outlet, then press and release start cord switch.



CAUTION

To avoid risk of damage to compressor windings, immediately disconnect (unplug) test cord from power source if compressor does not start. Damage to compressor windings occurs if windings remain energized when compressor is not running.

If compressor runs when direct wired, it is working properly. Malfunction is elsewhere in system.

If compressor does not start when direct wired, recover system at high side. After the system is recovered, repeat compressor direct wire test.

If compressor runs after system is recovered (but would not operate when wired direct before recovery) a restriction in sealed system is indicated.

If motor does not run when wired direct after recovery, replace faulty compressor.

Service Procedures



WARNING

To avoid risk of electrical shock, personal injury, or death, disconnect electrical power source to unit, unless test procedures require power to be connected. Discharge capacitor through a 10,000 ohm resistor before attempting to service. Ensure all ground wires are connected before certifying unit as repaired and/or operational.

Dehydrating Sealed Refrigeration System

Moisture in a refrigerator sealed system exposed to heat generated by the compressor and motor reacts chemically with refrigerant and oil in the system and forms corrosive hydrochloric and hydrofluoric acids. These acids contribute to breakdown of motor winding insulation and corrosion of compressor working parts, causing compressor failure.

In addition, sludge, a residue of the chemical reaction, coats all surfaces of sealed system, and will eventually restrict refrigerant flow through capillary tube.

To dehydrate sealed system, evacuate system (see paragraph *Evacuation*).

Leak Testing



DANGER

To avoid risk of serious injury or death from violent explosions, NEVER use oxygen or acetylene for pressure testing or clean out of refrigeration systems. Free oxygen will explode on contact with oil. Acetylene will explode spontaneously when put under pressure.

It is important to check sealed system for refrigerant leaks. Undetected leaks can lead to repeated service calls and eventually result in system contamination, restrictions, and premature compressor failure.

Refrigerant leaks are best detected with halide or electronic leak detectors.

Testing Systems Containing a Refrigerant Charge

1. Stop unit operation (turn refrigerator off).
2. Holding leak detector exploring tube as close to system tubing as possible, check all piping, joints, and fittings.

NOTE: Use soap suds on areas leak detector cannot reach or reliably test.

Testing Systems Containing No Refrigerant Charge

1. Connect cylinder of nitrogen, through gauge manifold, to process tube of compressor and liquid line strainer.
2. Open valves on nitrogen cylinder and gauge manifold. Allow pressure to build within sealed system.
3. Check for leaks using soap suds.

If a leak is detected in a joint, do not to attempt to repair by applying additional brazing material. Joint must be disassembled, cleaned and rebrazed. Capture refrigerant charge (if system is charged), unbrazed joint, clean all parts, then rebraze.

If leak is detected in tubing, replace tubing. If leak is detected in either coil, replace faulty coil.

Service Procedures



WARNING

To avoid risk of electrical shock, personal injury, or death, disconnect electrical power source to unit, unless test procedures require power to be connected. Discharge capacitor through a 10,000 ohm resistor before attempting to service. Ensure all ground wires are connected before certifying unit as repaired and/or operational.

Restrictions

Symptoms

Restrictions in sealed system most often occur at capillary tube or filter drier, but can exist anywhere on liquid side of system.

Restrictions reduce refrigerant flow rate and heat removal rate. Wattage drops because compressor is not circulating normal amount of refrigerants.

Common causes of total restrictions are moisture, poorly soldered joints, or solid contaminants. Moisture freezes at evaporator inlet end of capillary tube. Solid contaminants collect in filter drier.

If restriction is on low side, suction pressure will be in a vacuum and head pressure will be near normal.

If restriction is on high side, suction pressure will be in a vacuum and head pressure will be higher than normal during pump out cycle.

Refrigeration occurs on low pressure side of partial restriction. There will be a temperature difference at the point of restriction. Frost and/or condensation will be present in most case at the point of restriction. Also, system requires longer to equalize.

Slight or partial restriction can give the same symptoms as refrigerant shortage including lower than normal back pressure, head pressure, wattage, and warmer temperatures.

Total restriction on the discharge side of compressor, when restriction is between compressor and first half of condenser, results in higher than normal head pressure and wattage while low side is being pumped out.

Testing for Restrictions

To determine if a restriction exists:

1. Attach gauge and manifold between suction and discharge sides of sealed system.
2. Turn unit on and allow pressure on each side to stabilize. Inspect condenser side of system. Tubing on condenser should be warm and temperature should be equal throughout (no sudden drops at any point along tubing).
 - If temperature of condenser tubing is consistent throughout, go to step 4.
 - If temperature of condenser tubing drops suddenly at any point, tubing is restricted at point of temperature drop (if restriction is severe, frost may form at point of restriction and extend down in direction of refrigerant flow in system). Go to step 5.

3. Visually check system for kinks in refrigeration line which is causing restriction. Correct kink and repeat step 2.
 4. Turn unit off and time how long it takes high and low pressure gauges to equalize:
 - If pressure equalization takes longer than 10 minutes, a restriction exists in the capillary tube or drier filter. Go to step 5.
 - If pressure equalization takes less than 10 minutes, system is not restricted. Check for other possible causes of malfunction.
 5. Recover refrigerant in sealed system.
- NOTE:** Before opening any refrigeration system, capture refrigerant in system for safe disposal.
6. Remove power from unit.



CAUTION

To avoid risk of personal injury or property damage, take necessary precautions against high temperatures required for brazing.

7. Remove and replace restricted device.
 8. Evacuate sealed system.
 9. Charge system to specification.
- NOTE:** Do not use captured or recycled refrigerant in Amana units. Captured or recycled refrigerant voids any Amana and/or compressor manufacturer's warranty.
- NOTE:** Charge system with exact amount of refrigerant. Refer to unit nameplate for correct refrigerant charge. Inaccurately charged system will cause future problems.

Service Procedures



WARNING

To avoid risk of electrical shock, personal injury, or death, disconnect electrical power source to unit, unless test procedures require power to be connected. Discharge capacitor through a 10,000 ohm resistor before attempting to service. Ensure all ground wires are connected before certifying unit as repaired and/or operational.

Evacuation and Charging



CAUTION

To avoid risk of fire, sealed refrigeration system must be air free. To avoid risk of air contamination, follow evacuation procedures exactly.

NOTE: Before opening any refrigeration system, EPA regulations require refrigerant in system to be captured for safe disposal.

Proper evacuation of sealed refrigeration system is an important service procedure. Usable life and operational efficiency greatly depends upon how completely air, moisture and other non-condensables are evacuated from sealed system.

Air in sealed system causes high condensing temperature and pressure, resulting in increased power requirements and reduced performance.

Moisture in sealed system chemically reacts with refrigerant and oil to form corrosive hydrofluoric and hydrochloric acids. These acids attack motor windings and parts, causing premature breakdown.

Before opening system, evaporator coil must be at ambient temperature to minimize moisture infiltration into system.

Evacuation

To evacuate sealed refrigeration system:

1. Connect vacuum pump, vacuum tight manifold set with high vacuum hoses, thermocouple vacuum gauge and charging cylinder as shown in illustration. Evacuation should be done through I.D. opening of tubes not through line piercing valve.
2. Connect low side line to compressor process tube.
3. Connect high side line to drier/process tube.
4. Evacuate both simultaneously. With valve "C" and "F" closed, open all other valves and start vacuum pump.

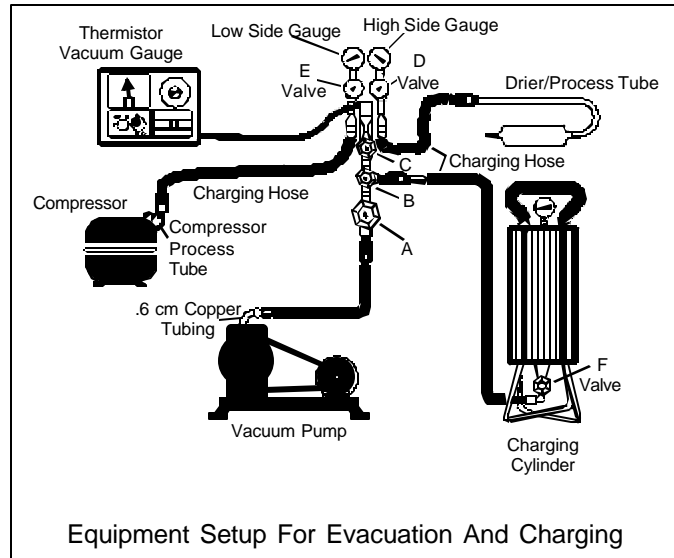

5. After compound gauge (low side) drops to approximately 29 inches gauge, open valve "C" to vacuum thermocouple gauge and take micron reading.
6. Continue evacuating system until vacuum gauge registers 600 microns.
7. At 600 microns, close valve "A" to vacuum pump and allow micron reading in system to balance. Micron level will rise.

NOTE: A high vacuum pump can only produce a good vacuum if oil in pump is not contaminated.

- If in 2 minutes, micron level stabilizes at 1000 microns or below, system is ready to be charged.
- If micron level rises above 1000 microns and stabilizes, open valve "A" and continue evacuating.
- If micron reading rises rapidly and does not stabilize, a leak still exists in system.

Close valve "A" to vacuum pump and valve "C" to vacuum gauge. Invert charging cylinder and open charging cylinder valve "F" to add partial charge for leak checking. With leak detector, check manifold connections and system for leaks. After locating leak, capture refrigerant, repair leak, and begin at step 1.

Service Procedures



WARNING

To avoid risk of electrical shock, personal injury, or death, disconnect electrical power source to unit, unless test procedures require power to be connected. Discharge capacitor through a 10,000 ohm resistor before attempting to service. Ensure all ground wires are connected before certifying unit as repaired and/or operational.

Charging

NOTE: Do not use captured or recycled refrigerant in Amana units. Captured or recycled refrigerant voids any warranty.

NOTE: Charge system with exact amount of refrigerant. Refer to unit serial plate for correct refrigerant charge. Inaccurately charged system will cause future problems.

To charge system:

1. Close valves "A" to vacuum pump and "C" to vacuum gauge and "E" to low side manifold gauge.
2. Set scale on dial-a-charge cylinder for corresponding HFC134a pressure reading.
3. Open valve "F" to charging cylinder and let exact amount of refrigerant flow from cylinder into system. Close valve.

Low side gauge pressure should rise shortly after opening charging cylinder valve as system pressure equalizes through capillary tube.

If pressure does not equalize, a restriction typically exists at capillary/drier braze joint.

4. If pressure equalizes, open valve "E" to low side manifold gauge and pinch off high side drier process tube.
5. Start compressor and draw remaining refrigerant from charging hoses and manifold into compressor through compressor process tube.
6. To check high side pinch-off drier process tube. Close valve "D" to high side gauge. If high side pressure rises, repeat high side pinch-off and open valve "D". Repeat until high side pinch-off does not leak.
7. Pinch-off compressor process tube and remove charging hose. Braze stub closed while compressor is operating.
8. Disconnect power. Remove charging hose and braze high side drier process tube closed.
9. Recheck for refrigerant leaks.

Refrigerant Charge

Refrigerant charge in all capillary tube systems is critical and exact amount is required for proper performance. Factory charges are shown on serial plate.

NOTE: Do not use refrigerant other than shown on serial plate.

Service Procedures



WARNING

To avoid risk of electrical shock, personal injury, or death, disconnect electrical power source to unit, unless test procedures require power to be connected. Discharge capacitor through a 10,000 ohm resistor before attempting to service. Ensure all ground wires are connected before certifying unit as repaired and/or operational.

HFC134a Service Information

HFC134a is alternative refrigerant for CFC12. HFC134a has an ozone depletion potential (ODP) factor of 0.0 and a global warming potential (GWP) factor of 0.27. HFC134a is not flammable and has acceptable toxicity levels. HFC134a is not interchangeable with CFC12. There are significant differences between HFC134a and CFC12 which must be considered when handling and processing refrigeration system.

Health, Safety, and Handling

Health, safety and handling considerations for HFC134A are virtually no different than those for CFC12.

Health, Safety, and Handling	CFC12	HFC134a
Allowable overall exposure limit	1,000 ppm	Same
Vapor exposure to skin	No effect	Same
Liquid exposure to skin	Can cause frostbite	Same
Vapor exposure to eye	Very slight eye irritant	Same
Liquid exposure to eye	Can cause frostbite	Same
Above minimum exposure limit	Can cause Asphyxiation, Tachycardia, and Cardia Arrhythmias	Same
Safety and handling	Wear appropriate skin and eye protection. Use with adequate ventilation.	Same
Spill management	Remove or extinguish ignition or combustion sources. Evacuate or ventilate area.	Same
Fire explosion hazards	May decompose if contact with flames and heating elements. Container may explode if heated due to resulting pressure rise. Combustion products are toxic.	Same
Disposal procedures	Recycle or reclaim.	Same

Comparison of CFC12 and HFC134a Properties

Properties/Characteristics	CFC12	HFC134a
Ozone Depletion Potential (ODP)	1.0*	0.0*
Global Warming Potential (GPW)	3.2*	0.27*
Molecular weight	121	102
Boiling point at 1 atmosphere	-22°F (-30°C)	-15°F (-126°C)
Vapor pressure at 77°F (25°C)	80 psig	82 psig
Liquid density at 77°F (25°C)	82 lb/ft ³	75 lb/ft ³
Flammability	No	No
High-side system operating Pressure at 65°F (18°C)	HFC134a approximately 3 psig higher than CFC12	
Low-side system operating Pressure at 65°F (18°C)	HFC134a approximately 2 psig lower than CFC12	



CAUTION

To minimize contamination, exercise extreme care when servicing HFC134A sealed systems.

- No trace of other refrigerants is allowed in HFC134a systems. Chlorinated molecules in other refrigerants such as CFC12, etc. will lead to capillary tube plugging.
- Ester oil is used in HFC134a systems. Do not use mineral oil. HFC134a and mineral oils cannot be mixed. If mineral oils were used in HFC134a systems, lubricant would not return to compressor and would cause early compressor failure. If significant amount of oil has been lost from compressor, replace oil rather than adding oil.
- Ester oils used in HFC134a systems are so hydroscopic that by the time an inadequate system performance is detected, oil will be saturated with moisture.
- CFC12 has much higher tolerance to system processing materials, such as drawing compounds, rust inhibitors, and cleaning compounds, than HFC134a. Such materials are not soluble in HFC134a systems. If materials were to be washed from system surfaces by ester oils, they could accumulate and eventually plug capillary tube.
- Care must be taken to minimize moisture entering HFC134a system. Do not leave compressor or system open to atmosphere for more than 10 minutes. Excessive moisture in HFC134a system will react with compressor oil and generate acid.
- Compressor must be replaced when performing low side leak repair.
- Drier filter must always be replaced with service drier filter, part #B2150504.

Important: Unbrazing drier filter from tubing will drive moisture from desiccant and into system, causing acids to form. Do not unbrazed filter drier from tubing. If CFC12 service drier was installed in HFC134A system, drier could overload due to excessive moisture.

- HFC134a compatible copper tubing, part #R0174075 (1/4" O.D. X 18" length) and part #R0174076 (5/16" O.D. X 24" length) must be used when replacing tubing.
- Avoid system contamination by using Towerdraw E610 evaporating oil, part # R0157532, when flaring, swagging, or cutting refrigeration tubing.

Service Procedures



WARNING

To avoid risk of electrical shock, personal injury, or death, disconnect electrical power source to unit, unless test procedures require power to be connected. Discharge capacitor through a 10,000 ohm resistor before attempting to service. Ensure all ground wires are connected before certifying unit as repaired and/or operational.

Replacement Service Compressor

HFC134a service compressors will be charged with ester oil and pressurized with dry nitrogen. Before replacement compressor is installed, pull out 1 rubber plug. A *pop* from pressure release should be heard. If a *pop* sound is not heard, do not use compressor. Positive pressure in compressor is vital to keep moisture out of ester oil. Do not leave compressor open to atmosphere for more than 10 minutes.

Compressor Testing Procedures



WARNING

To avoid death or severe personal injury, never use oxygen, air or acetylene for pressure testing or clean out of refrigeration system. Use of oxygen, air, or acetylene may result in violent explosion. Oxygen may explode on contact with oil and acetylene will spontaneously explode when under pressure.

Refer to Technical Data Sheet "Temperature Relationship Chart" for operating watts, test points, and temperature relationship test for unit being tested.

- Temperature testing is accomplished by using 3 lead thermocouple temperature tester in specific locations. Test point T-1 is outlet on evaporator coil and T-2 is inlet. Test point T-3 is suction tube temperature midway between where armaxflex ends and suction port of compressor (approximately 12 inches from compressor).
- Thermocouple tips should be attached securely to specified locations.
- Do not test during initial *pull down*. Allow one off cycle or balanced temperature condition to occur before proceeding with testing.
- Refrigerator must operate minimum of 20 minutes after thermocouples are installed.
- Turn control to colder to obtain required on time.
- Wattage reading must be recorded in conjunction with temperature test to confirm proper operation.
- Suction and head pressures are listed on "Temperature and Relationship Chart". Normally these are not required for diagnosis but used for confirmation on systems which have been opened.

Brazing



CAUTION

To avoid risk of personal injury or property damage, take necessary precautions against high temperatures required for brazing.

Satisfactory results require cleanliness, experience, and use of proper materials and equipment.

Connections to be brazed must be properly sized, free of rough edges, and clean.

Generally accepted brazing materials are:

- **Copper to copper joints:** SIL-FOS (alloy of 15 percent silver, 80 percent copper, and 5 percent phosphorous). Use without flux. Recommended brazing temperature is approximately 1400°F. **Do not use for copper to steel connection.**
- **Copper to steel joints:** SILVER SOLDER (alloy of 30 percent silver, 38 percent copper, 32 percent zinc). Use with fluoride based flux. Recommended brazing temperature is approximately 1200°F.
- **Steel to steel joints:** SILVER SOLDER (see copper to steel joints).
- **Brass to copper joints:** SILVER SOLDER (see copper to steel joints).
- **Brass to steel joints:** SILVER SOLDER (see copper to steel joints).

Refrigerant Flow

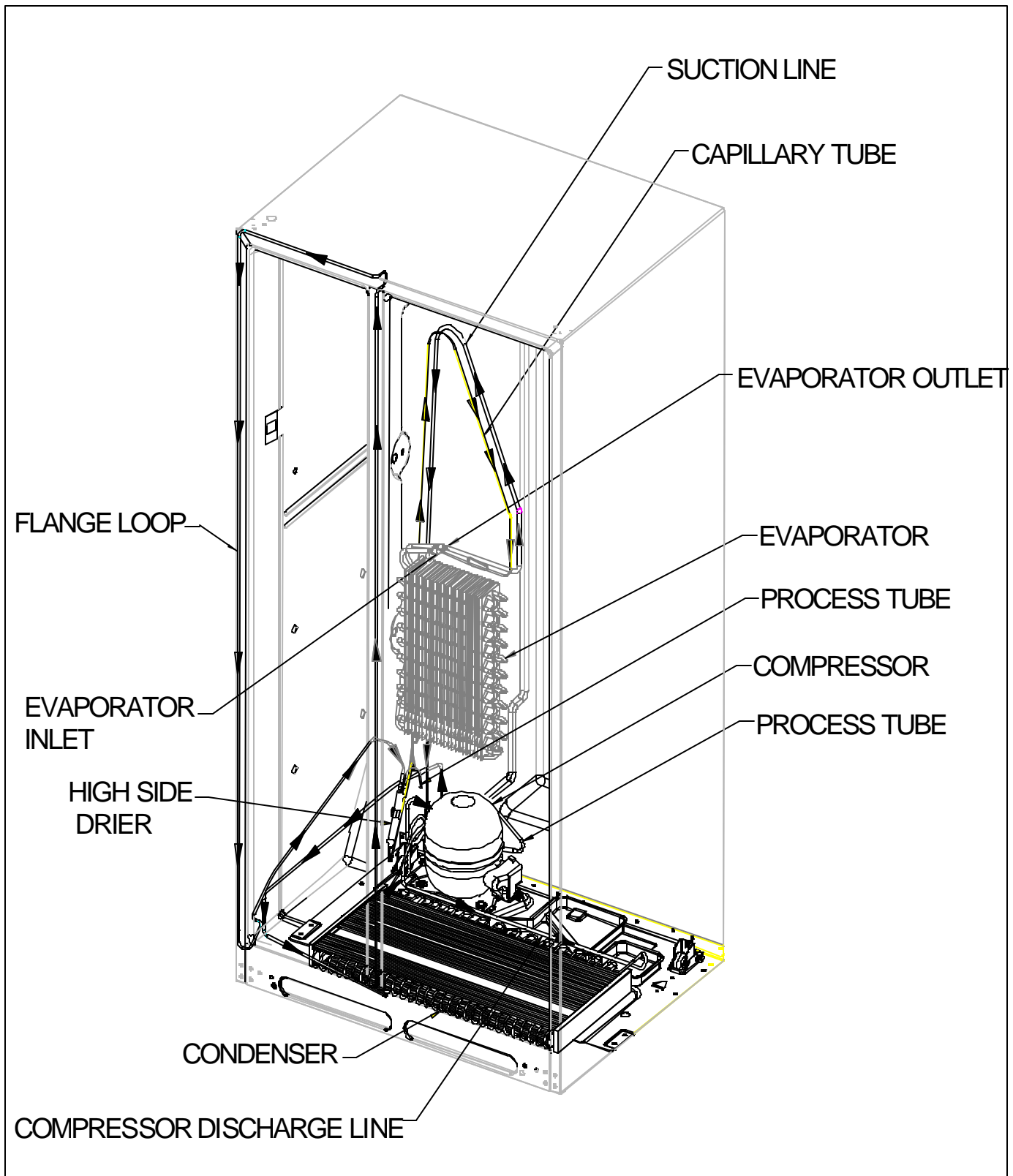

22, 24, 26 cu. ft. Side by Side
Refrigerant Flow Diagram

Cabinet Air Flow

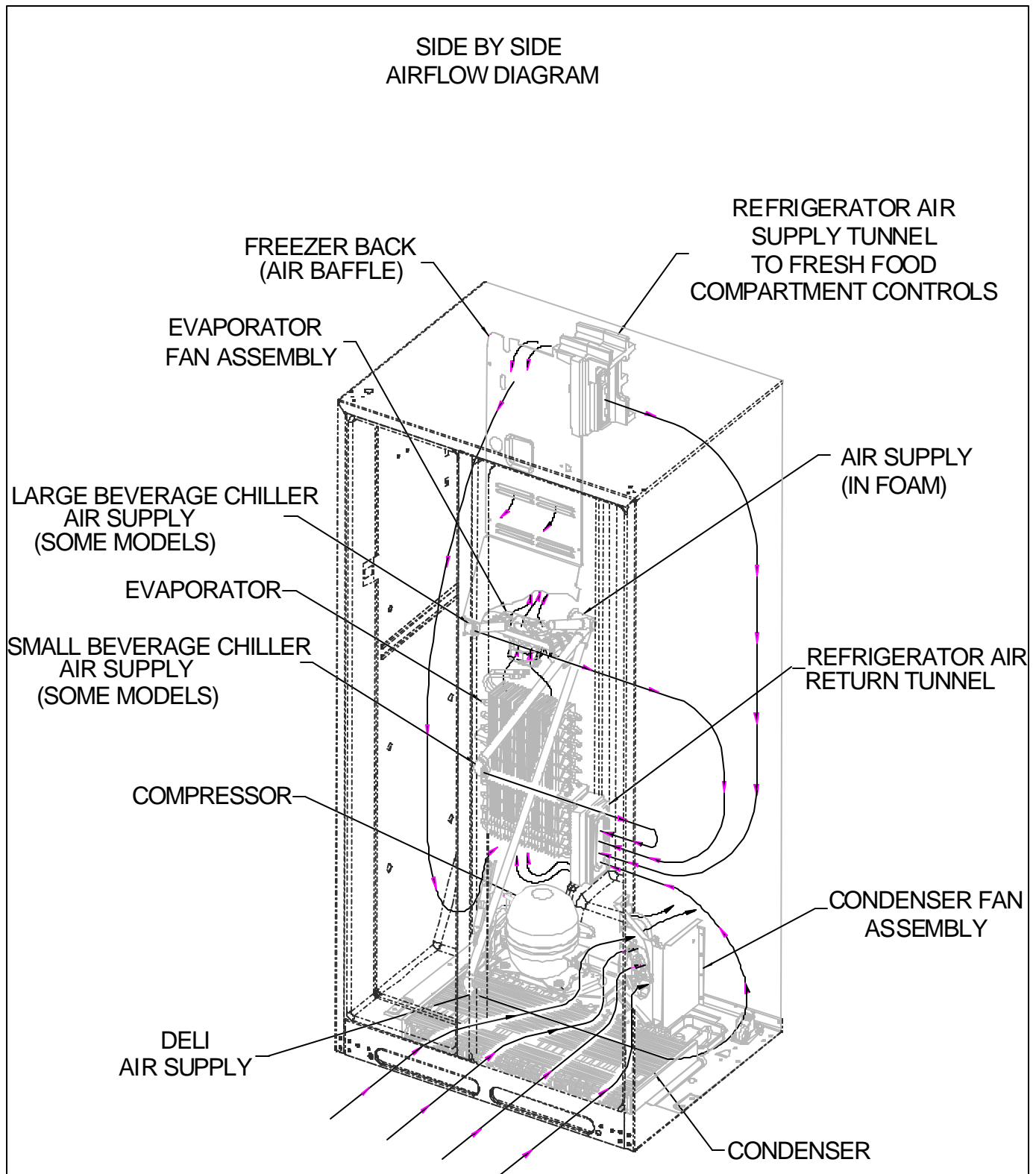

**24, 26 cu. ft. Side by Side
Cabinet Air Flow Diagram**

Cabinet Air Flow

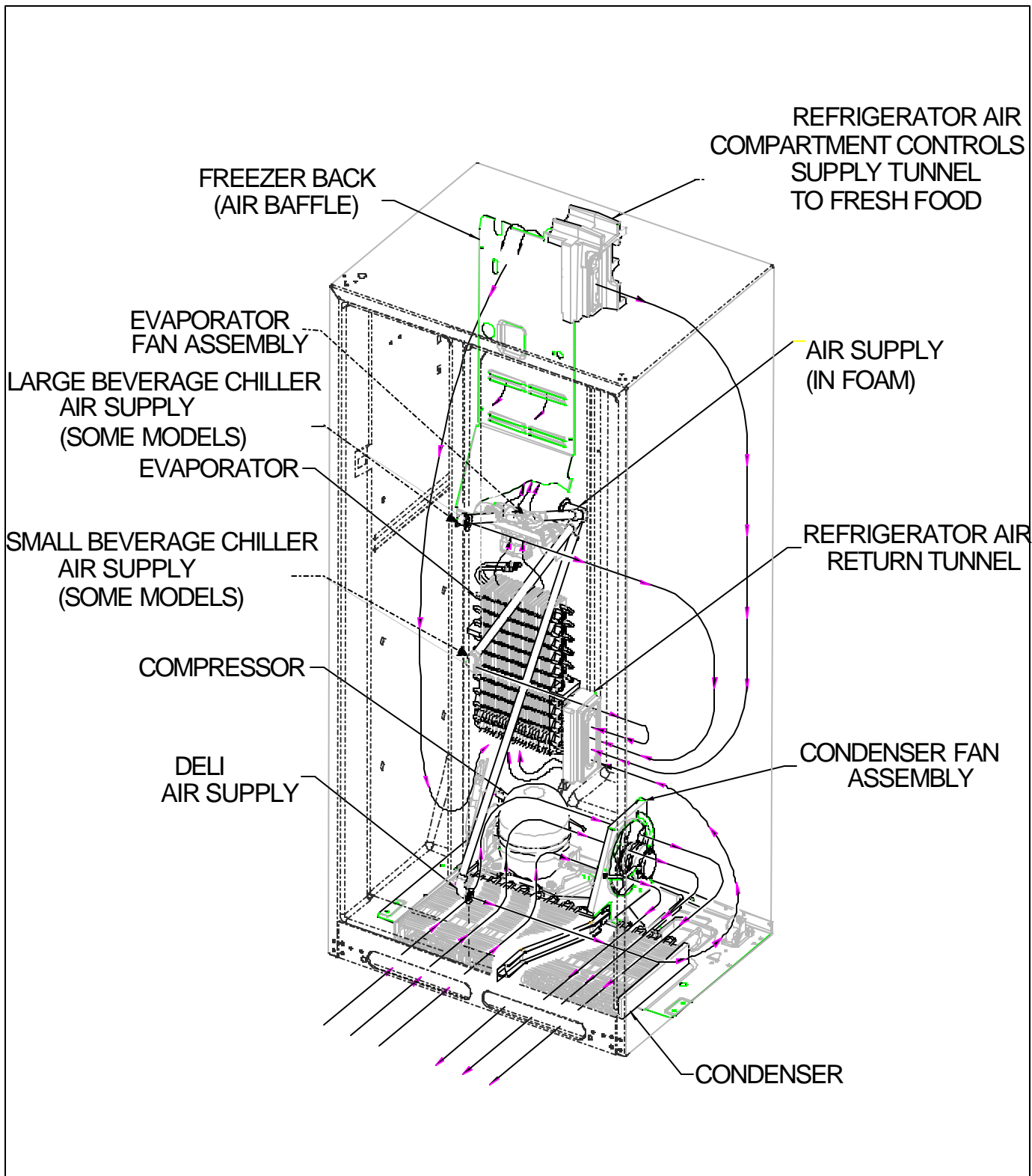

22 cu. ft. Side by Side
Cabinet Air Flow Diagram

Ice and Water Dispenser Diagram

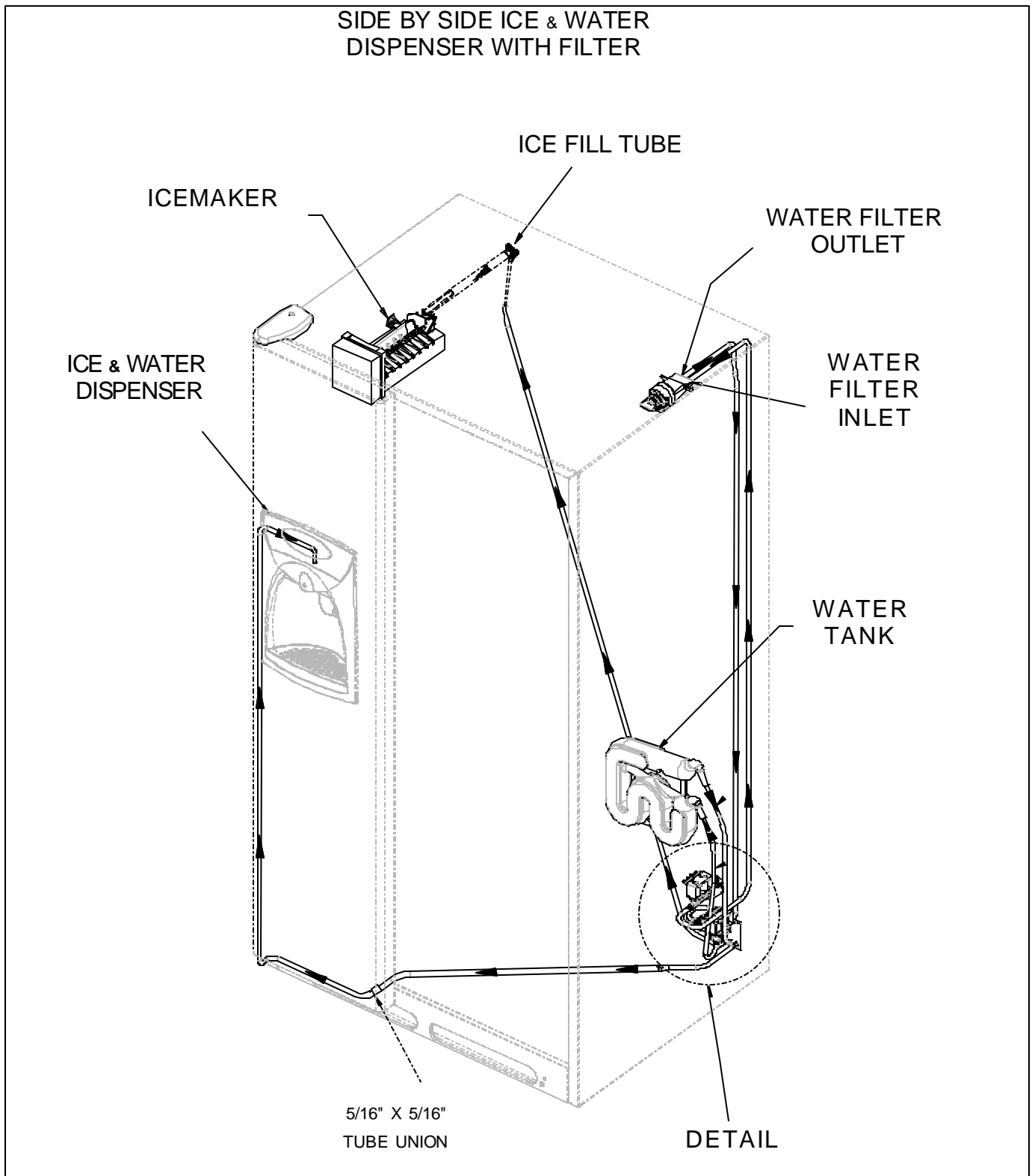

22, 24, 26 cu. ft. Model Side by Side
Ice and Water Flow Diagram

Water Valves Diagram

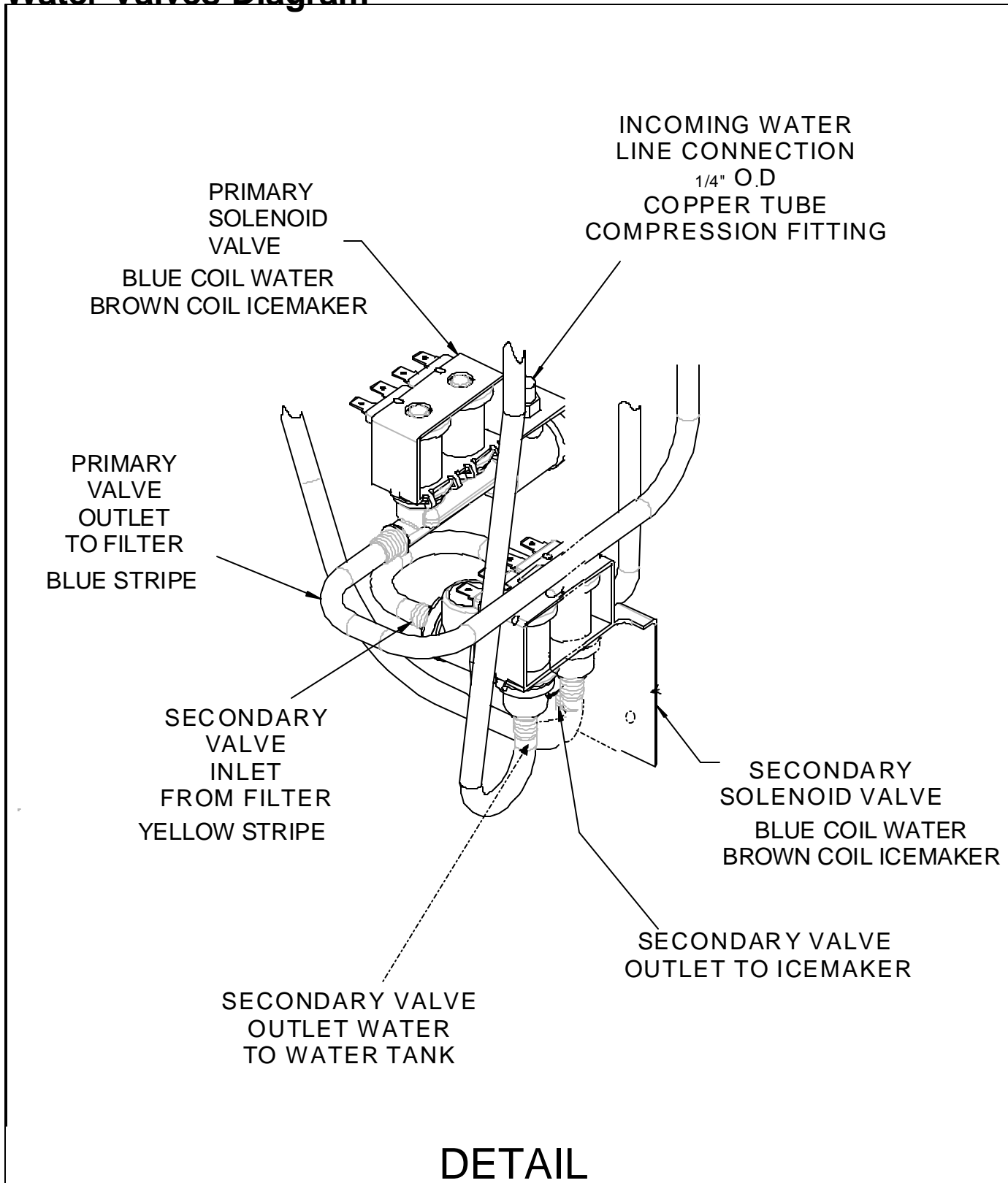

22, 24, 26 cu. ft. Model Side by Side
Ice and Water Flow Diagram

Typical External Sweat Pattern

Classification of condensation:

- 1 = Haze or Fog
- 2 = Beading
- 3 = Beads or Small Drops
- 4 = Drops Running Together

Conditions after 4 hour laboratory test:

Ambient: 90°F, 84% relative humidity
 Refrigerator compartment at 40°F
 Freezer compartment at 0°F

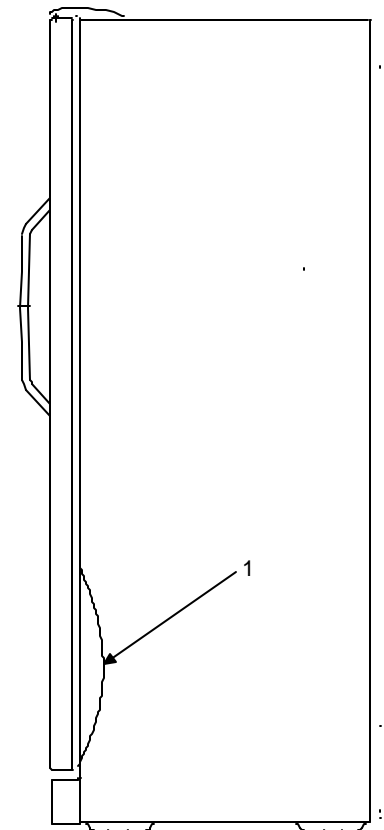
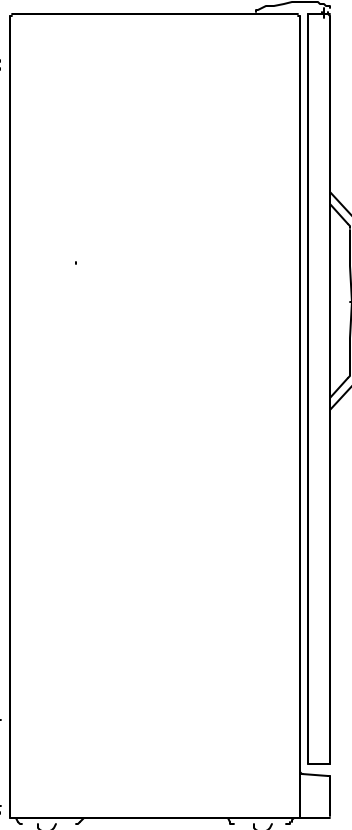
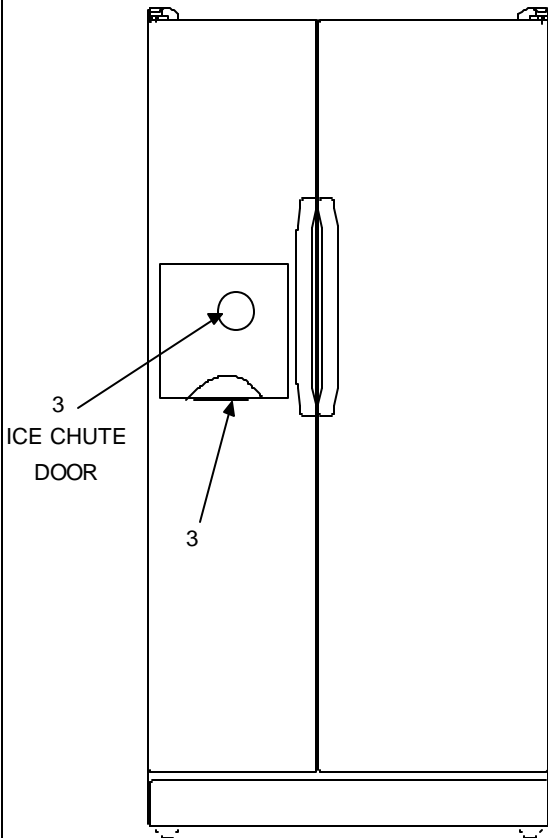
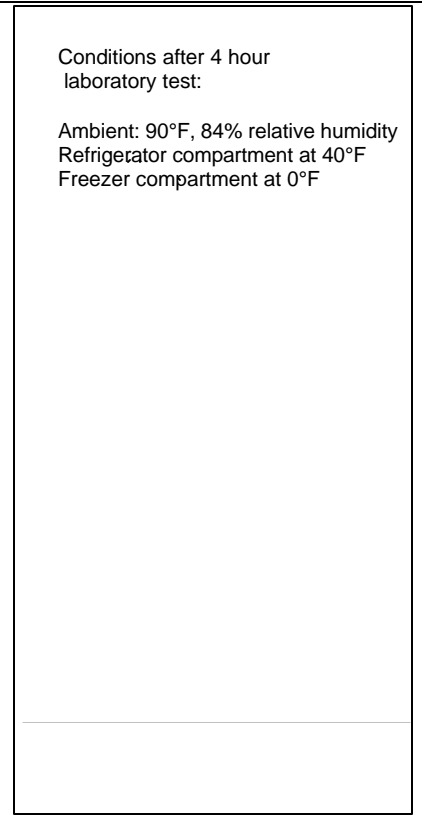
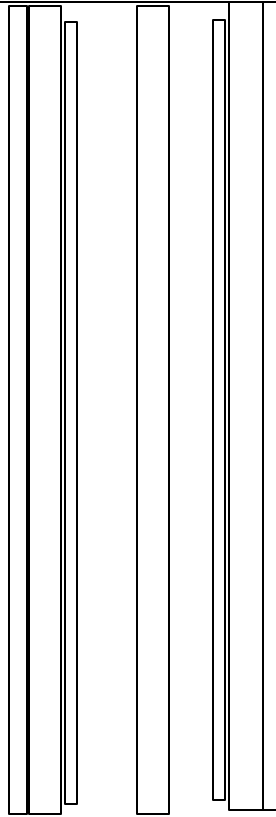
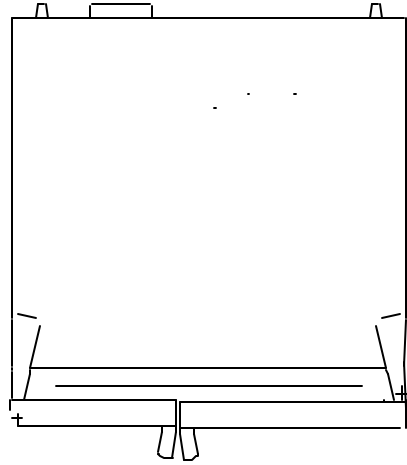
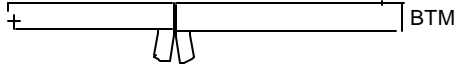

Troubleshooting Chart



WARNING

To avoid risk of electrical shock, personal injury, or death, disconnect electrical power source to unit, unless test procedures require power to be connected. Discharge capacitor through a resistor before attempting to service. Ensure all ground wires are connected before certifying unit as repaired and/or operational.

Troubleshooting chart on following pages contains symptoms that may be seen in malfunctioning units. Each symptom is accompanied by one or more possible causes and by a possible remedy or test to determine if components are working properly.

Symptom	Possible Causes	Corrective Action
Unit does not run	No power to unit	Check for power at outlet. Check fuse box/circuit breaker for blown fuse or tripped breaker. Replace or reset.
	Faulty power cord	Check with test light at unit; if no circuit and current is indicated at outlet, replace or repair.
	Low voltage	Check input voltage for proper voltage. Take appropriate action to correct voltage supply problem.
	Faulty motor or freezer temperature control	Check all connections are tight and secure. Jumper across terminals of control. If unit runs, replace control.
	Faulty timer	Check with test light. Replace if necessary.
	Faulty relay	Check relay. Replace if necessary.
	Faulty compressor	Check compressor motor windings for opens/shorts. Perform compressor direct wiring test. Replace if necessary.
	Faulty overload	Check overload for continuity. NOTE: Ensure compressor/overload are below trip temperature before testing. Replace if necessary.
Refrigerator section too warm	Excessive door opening	Consumer education
	Overloading of shelves	Consumer education
	Warm or hot foods placed in cabinet	Consumer education
	Cold control set too warm	Set control to colder setting.
	Poor door seal	Level cabinet. Adjust hinges. Replace gasket.
	Refrigerator airflow	Check damper is opening by removing grille. With door open, damper should open. Replace if faulty. Turn control knob to colder position.
	Interior light remains on	Check switch. Replace if necessary.
	Faulty condenser fan or evaporator fan	Check fan and wiring. Replace if necessary.
	Faulty compressor	Replace compressor.

Troubleshooting Chart



WARNING

To avoid risk of electrical shock, personal injury, or death, disconnect electrical power source to unit, unless test procedures require power to be connected. Discharge capacitor through a resistor before attempting to service. Ensure all ground wires are connected before certifying unit as repaired and/or operational.

Symptom	Possible Causes	Corrective Action
Refrigerator section too cold	Refrigerator temperature control set too cold	Adjust refrigerator temperature control.
	Refrigerator airflow not properly adjusted	Check air flow.
Freezer and refrigerator sections too warm	Temperature controls set too warm	Reset temperature controls.
	Poor door seal	Level cabinet. Adjust hinges. Replace gasket.
	Dirty condenser or obstructed grille	Check condenser and grille. Clean.
	Faulty control	Test control. Replace if failed.
	Refrigerant shortage or restriction	Check for leak or restriction. Repair, evacuate and recharge system.
Freezer section too cold	Freezer temp control set too cold	Adjust freezer temperature control.
	Faulty control	Test control. Replace if failed.
	Cold control capillary not properly clamped to evaporator	Reposition clamp and tighten.
Unit runs continuously	Temperature control set too cold	Adjust temperature control.
	Dirty condenser or obstructed grille	Check condenser and grille. Clean.
	Poor door seal	Level cabinet. Adjust hinges. Replace gasket.
	Interior light remains on	Check switch. Replace if necessary.
	Faulty condenser fan or evaporator fan	Check fan and wiring. Replace if necessary.
	Faulty control	Test control. Replace if failed.
	Refrigerant shortage or restriction	Check for leak or restriction. Repair, evacuate and recharge system.
	Refrigerant overcharge	Check for overcharge. Evacuate and recharge system.
	Air in system	Check for low side leak. Repair, evacuate and recharge system.
	Unit runs continuously. Temperature normal.	Ice on evaporator
Unit runs continuously. Temperature too cold.	Faulty defrost thermostat	Check thermostat. Replace if necessary.
Noisy operation	Loose flooring or floor not firm	Repair floor or brace floor.
	Cabinet not level	Level cabinet.
	Tubing in contact with cabinet, other tubing, or other metal	Adjust tubing.
	Drip pan vibrating	Adjust drain pan.
	Fan hitting another part	Ensure fan properly aligned and all attaching hardware and brackets are tight and not worn. Tighten or replace.
	Worn fan motor bearings	Check motor for loss of lubricant or worn bearings. Replace if necessary.
	Compressor mounting grommets worn or missing. Mounting hardware loose or missing	Tighten hardware. Replace grommets if necessary.
	Free or loose parts causing or allowing noise during operation	Inspect unit for parts that may have worked free or loose or missing screws. Repair as required.

Troubleshooting Chart



WARNING

To avoid risk of electrical shock, personal injury, or death, disconnect electrical power source to unit, unless test procedures require power to be connected. Discharge capacitor through a resistor before attempting to service. Ensure all ground wires are connected before certifying unit as repaired and/or operational.

Symptom	Possible Causes	Corrective Action
Frost or ice on evaporator	Defrost thermostat faulty	Check defrost thermostat. Replace if failed.
	Evaporator fan faulty	Check fan motor. Replace if failed.
	Defrost heater remains open	Check defrost heater continuity. Replace if failed.
	Defrost control faulty	Check control and replace if failed.
	Open wire or connector	Check wiring and connections. Repair as necessary.
	Refrigerant shortage or restriction	Check for leak or restriction. Repair, evacuate and recharge system.
Unit starts and stops frequently (cycles on and off)	Loose wire or thermostat connections	Check wiring and connections. Repair as necessary.
	Supply voltage out of specification	Check input voltage. Correct any supply problems.
	Overload protector open	Check overload protector for continuity. If open, replace overload. NOTE: Ensure overload/compressor are below trip temperature before testing.
	Faulty compressor motor capacitor (some compressors do not require motor capacitor)	Check capacitor for open/short. Replace if necessary. NOTE: Discharge capacitor before testing.
	Faulty fan motor	Check fan motor. Replace if failed.
	Restricted air flow	Check condenser and grille for dirt. Clean.
	Refrigerant shortage or restriction	Check for leak or restriction. Repair, evacuate and recharge system.

System Diagnosis

CONDITION	SUCTION PRESSURE VARIATION FROM NORMAL	HEAD PRESSURE VARIATION FROM NORMAL	T1 INLET TEMPERATURE VARIATION FROM NORMAL	T2 OUTLET TEMPERATURE VARIATION FROM NORMAL	T3 SUCTION TEMPERATURE VARIATION FROM NORMAL	WATTAGE VARIATION FROM NORMAL
Refrigerant Overcharge	Increase	Increase	Warmer	Warmer	Colder	Increase
Shortage of Refrigerant	Decrease	Decrease or Increase See Text	Colder	Warmer	Warmer	Decrease
Partial Restriction	Decrease	Decrease or Increase See Text Note 2	Colder	Warmer	Warmer	Decrease
Air in System	Near Normal	Increase	Warmer	Warmer	Warmer	Increase
Low Ambient Installations (High Ambients the Reverse)	Decrease	Decrease	Colder	Warmer	Warmer	Decrease
Additional Heat Load	Increase	Increase	Warmer	Warmer	Warmer	Increase
Inefficient Compressor	Increase	Normal or Decrease	Warmer or Colder	Warmer	Warmer	Decrease

Symptoms of an Overcharge

- Above normal freezer temperatures.
- Longer than normal or continuous run.
- Freezing in refrigerator, especially on forced air meatkeeper models.
- Higher than normal suction and head pressure.
- Higher than normal wattage.
- Evaporator inlet and outlet temperatures warmer than normal.
- Suction tube temperature below ambient. Always check for separated heat exchanger when suction temperature is colder than ambient.

Various conditons could indicate an overcharge. For example, if the cooling coil is not defrosted at regular intervals, due to a failure of the defrost system, the refrigerant will "flood out" and cause the suction line to frost or sweat. The cause of this problem should be corrected rather than to purge refrigerant from the sytem. Running the freezer section colder than necessary (-2 to -1 F. is considered normal package temperatures) or continuous running of the compressor for a variety of reasons, or the freezer fan motor not running, may give the indication of an overcharge.

Symptoms of Refrigeration Shortage

- Rise in food product temperature in both compartments. (See Note 1 below.)
- Long or continuous run time.
- Look for obvious traces of oil that would occur due to a leak or cracked refrigerant line.
- Lower than normal wattage.
- Compressor will be hot to touch because of the heat generated by the motor windings from long continuous running. It will not be as hot as it would be with a full charge and long run times for some other reason such as a dirty condenser.
- Depending on the amount of the shortage, the condenser will not be hot, but closer to room temperature. The capillary tube will be warmer than normal from a slight shortage.
- If the leak is on the high side of the system, both gauges will show lower than normal readings and will show progressively lower readings as this charge becomes less. The suction pressure guage will probably indicate a vacuum.
- If the leak is on the low side of the system the suction pressure guage will be lower than normal - probably in a vacuum - and the head pressure gauge will be higher than normal. It will probably continue to become higher because air drawn in through the leak is compressed by the compressor and accumulates in

System Diagnosis

the high side (condenser) of the system.

- Only partial frosting of evaporator instead of even frosting of entire coil.

NOTE 1: Usually the first thing that is noticed by the user is a rise in temperature foods. Although temperatures will rise in both the freezer section and the food compartment, the frozen meats and vegetables will not thaw immediately. The customer doesn't associate the problem with the freezer section and will first notice that milk and other food beverages are not cold enough.

Under some circumstances, such as in the case of forced air meatkeeper model with a slight shortage of refrigerant, freezing in the food compartment may be experienced due to the additional running time. With a refrigerant leak, however, it always gets worse and as the refrigerant charge decreases the temperature will continue to rise.

With a shortage of refrigerant the capillary line will not have a full column of liquid. As a result, there is a noticeable hissing sound in the evaporator. This should not be mistaken for the regular refrigerant boiling sounds that would be considered normal.

Symptoms of a Restriction

Always remember refrigeration (cooling) occurs on the low pressure side of a partial restriction (obviously a total restriction will completely stop the circulation of refrigerant and no cooling will take place).

Physically feel the refrigeration lines when a restriction is suspected. The most common place for a restriction is at the drier-filter or at the capillary tube inlet or outlet. If the restriction is not total there will be a temperature difference at the point of restriction, the area on the evaporator side will be cooler. In many cases frost and/or condensation will be present. A longer time is required for the system to equalize.

Any kinked line will cause a restriction so the entire system should be visually checked.

A slight restriction will give the same indications as a refrigerant shortage with lower than normal back pressure, head pressure, and wattage, warmer product temperatures.

NOTE 2: If a total restriction is on the discharge side of the compressor, higher than normal head pressures and wattages would result. This is true only while the low side is being pumped out and if the restriction was between the compressor and the first half of the condenser.

To diagnose for a restriction versus a refrigerant shortage, discharge the system, replace the drier-filter, evacuate and recharge with the specified refrigerant charge. If the unit performs normally three possibilities exist: 1) refrigerant loss, 2) partially restricted drier-filter, and 3) moisture in system.

If the unit performs as it previously did you may have a restricted capillary line or condenser or kinked line. Find the point of restriction and correct it.

A restriction reduces the flow rate of the refrigerant and consequently reduces the rate of heat removal. Complete restriction may be caused by moisture, solid contaminants in the system, or a poorly soldered joint. Moisture freezes at the evaporator inlet end of the capillary tube or solid contaminants collect in the drier-filter. The wattage drops because the compressor is not circulating the usual amount of refrigerant.

As far as pressure readings are concerned, if the restriction, such as a kinked line or a joint soldered shut is anywhere on the low side, the suction pressure would probably be in a vacuum while the head pressure will be near normal. If the restriction is on the high side, the suction pressure, again, will probably be in a vacuum while the head pressure will be higher than normal during the pump out period described earlier. In either case, it will take longer than the normal ten minutes or so for the head pressure to equalize with the low side after the compressor stops.

Symptoms of Air in System

This can result from a low side leak or improper servicing. If a leak should occur on the low side, the temperature control would not be satisfied; thus, continuous running of the compressor would result. The compressor would eventually pump the low side into a vacuum drawing air and moisture into the system. Air and R134A do not mix so the air pressure would be added to the normal head pressure, resulting in higher than normal head pressures.

One way to determine if air is in the system is to read the head pressure gauge with the product off and evaporator and condenser at the same temperature and then take the temperature on the condenser outlet tube. This temperature should be within 3° or 4° F. of what the Pressure-Temperature Relation chart shows for the given idle head pressure. If the temperature of the condenser outlet is considerably lower than the idle head pressure of the gauge this would indicate there is air in the system.

Thorough leak checking is necessary. Correct the source of the leak. Do not attempt to purge off the air because this could result in the system being undercharged. It is best to discharge, replace drier, evacuate and recharge with the specified refrigerant charge.

System Diagnosis

Symptoms of Low or High Ambient Temperature Installation

Lower ambient air temperature reduces the condensing temperature and therefore reduces the temperature of the liquid entering the evaporator. The increase in refrigeration effect due to operation in a lower ambient results in a decrease in power consumption and run time. At lower ambients there is a reduction in cabinet heat leak which is partially responsible for lower power consumption and run time.

An increase in refrigeration effect cannot be expected below a certain minimum ambient temperature. This temperature varies with the type and design of the product.

Generally speaking, ambient temperatures cannot be lower than 60° F. without affecting operating efficiency. Conversely, the higher the ambient temperature the higher the head pressure must be to raise the high side refrigerant temperature above that of the condensing medium. Therefore, head pressure will be higher as the ambient temperature rises. Refrigerators installed in ambient temperatures lower than 60° F. will not perform as well because the pressures within the system are generally reduced and unbalanced. This means that the lower head pressure forces less liquid refrigerant through the capillary line. The result is the symptoms of a refrigerant shortage. The lower the ambient temperature the more pronounced this condition becomes.

When a point where the ambient temperature is below the cut-in of the Temperature Control is reached, the compressor won't run.

The drain traps will freeze in ambient temperatures of 32° F.

Heat Load

A greater heat load can result from the addition of more than normal supply of foods, such as after doing the weekly shopping. Other items contributing to an additional heat load would be excessive door openings, poor door sealing, interior light remaining on, etc.

An increase in heat being absorbed by the refrigerant in the evaporator will affect the temperature and pressure of the gas returning to the compressor. Compartment temperatures, power consumption, discharge, and suction pressures are all affected by heat load.

Pressures will be higher than normal under heavy heat load.

Disassembly Procedures



WARNING

To avoid risk of electrical shock, personal injury, or death, disconnect electrical power source to unit, unless test procedures require power to be connected. Discharge capacitor through a resistor before attempting to service. Ensure all ground wires are connected before certifying unit as repaired and/or operational.

Refrigerator Compartment

Upper Light Sockets and Lens

1. Unsnap light cover from top of compartment.
2. Remove screws holding light assembly to top of cabinet.
3. Light assembly can be removed after disconnecting wires.
4. Light sockets can be removed by squeezing tabs inward to release sockets.
5. Reverse procedure to reassemble.

Light Switch

Use a taped putty knife to carefully pry light switch out of liner. When light switch is free of compartment liner, remove wires from light switch. Remove light switch from unit.

Cold Control, Defrost Timer, Damper Control Assembly

1. Remove cold control and fresh food control knobs.
2. Remove screw just between knobs and on right side of control cover.
3. Remove cover by pulling cover to the right and forward off tabs.
4. Disconnect wiring harness from cabinet.
5. Remove screws from side holding complete assembly to center bulkhead.
6. Release front tab by depressing rearward on tab.
7. Pull complete assembly carefully to your right and out from center bulkhead.
8. Carefully pull cold control capillary out of center bulkhead sleeve.
9. Reverse procedure to reassemble.

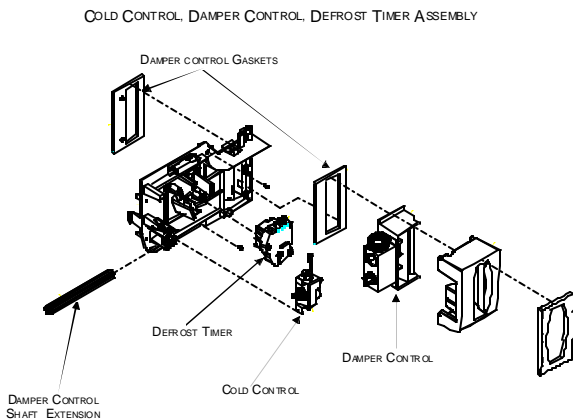

Freezer Cold Control

1. See disassembly instructions for removal of cold control, defrost timer, damper control assembly.
2. With assembly out disconnect wires and ground to cold control.
3. Carefully detach capillary tube from assembly holder.
4. Depress tab at bottom of cold control to release control from assembly.
5. Reverse procedure to reassemble.

Defrost Timer (some models)

1. Remove cold control and fresh food control knobs.
2. Remove screw just between knobs and on right side of control cover.
3. Remove cover by pulling cover to the right and forward off tabs.
4. Release tabs holding defrost timer to assembly.
5. Remove timer by lifting off of assembly.
6. Disconnect harness from defrost timer.
7. Reverse procedure to reassemble.

Adaptive Defrost Control (ADC) (some models)

1. Remove cold control and fresh food control knobs.
2. Remove screw just between knobs and on right side of control cover.
3. Remove cover by pulling cover to the right and forward off tabs.
4. Release front left tab to remove ADC cover.
5. Remove ADC board from locating tabs.
6. Disconnect harness from ADC board.
7. Reverse procedure to reassemble.

ADC CONTROL HOUSING

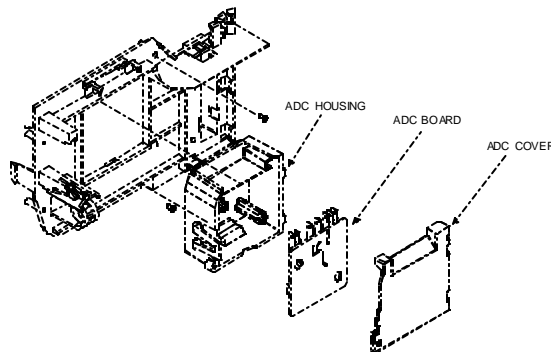

Disassembly Procedures



WARNING

To avoid risk of electrical shock, personal injury, or death, disconnect electrical power source to unit, unless test procedures require power to be connected. Discharge capacitor through a resistor before attempting to service. Ensure all ground wires are connected before certifying unit as repaired and/or operational.

Damper Control

1. Remove cold control and fresh food control knobs.
2. Remove screw just between knobs and on right side of control cover.
3. Remove cover by pulling cover to the right and forward off tabs.
4. Slide off styrafoam block. Retain for future use.
5. Pull shaft extension free of control.

NOTE: Observe wide and narrow clip leg orientation of shaft and damper cover.

6. Release side tabs holding damper control to assembly.
7. Lift damper control off of assembly

NOTE: Retain damper gasket for future use.

8. Reverse procedure to reassemble.

Water Filter Assembly

1. Remove filter cover opening cover and pulling rear left side of cover to the left to release cover from holding pin.
2. Filter head can be released from holding bracket by opening tabs on left side filter head and pulling downward and to your left to release filter head.
3. Tubing needs to be disconnected from water valves in the machine compartment. (see water valve removal)
4. After tubing is loose from water valves pull the filter head and tubing out the front of unit.
5. Reverse procedure to reassemble.

NOTE: Make sure to note tubing end colors when reinstalling new head and tubing assembly.

Water Tank Assembly

1. Remove crisper drawers from fresh food compartment.
2. Remove hex screw holding water tank to rear bulkhead.
3. On rear of cabinet remove hex screws holding water valve cover plate.
4. Remove plate and tubing away from cabinet to expose water valves and tubing.
5. Disconnect water tube from secondary valve coming from water tank, remove compression nut from tubing.
6. On front of unit remove toe grill and disconnect water coupler going to water dispenser
7. Remove compression nut from water tubing on cabinet side of connection.
8. From rear of cabinet pull water tube out of conduit going to dispenser.

9. From inside of fresh food compartment pull tubing up and out of cabinet to complete removal of water tank.
10. Reverse procedure to reassemble.

Crisper Light Cover and Socket

1. Push down and forward on light cover and lift off tabs.
2. Remove light bulb and pry socket with taped putty knife to release socket from liner.
3. Disconnect wires from socket.
4. Reverse procedure to reassemble.

Freezer Compartment

Freezer Light socket

1. Remove auger ice bucket and fast freeze shelf.
2. Remove auger motor assembly. (see auger motor assembly removal.
3. Remove light bulbs.
4. Disconnect wiring from light sockets.
5. Squeeze retaining tab to release sockets
6. Reverse procedure to reassemble.

Auger Motor Assembly

1. Remove auger ice bucket and fast freeze shelf.
2. Remove light bulbs
3. Remove two hex head screws, one from each side of cover.
4. Lift and slide assembly toward the front, disconnect wiring harness and remove assembly.

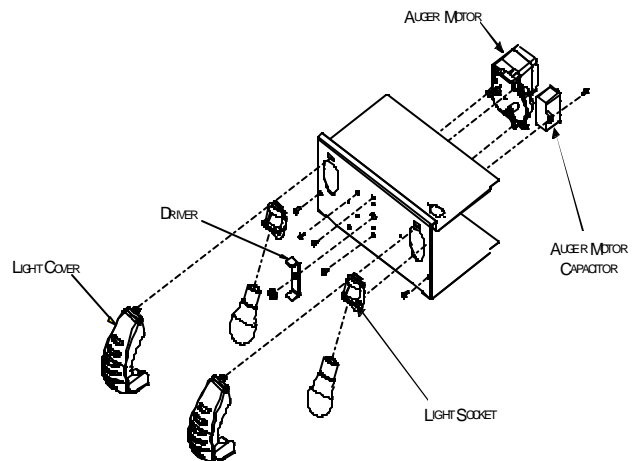

Auger Motor

1. Remove auger drive hex nut.
2. Remove three hex nuts holding auger motor to assembly.
3. Disconnect wires from auger motor capacitor.
4. Reverse procedure to reassemble.

Disassembly Procedures



WARNING

To avoid risk of electrical shock, personal injury, or death, disconnect electrical power source to unit, unless test procedures require power to be connected. Discharge capacitor through a resistor before attempting to service. Ensure all ground wires are connected before certifying unit as repaired and/or operational.

Auger Motor Capacitor

1. Remove auger ice bucket and fast freeze shelf.
2. Remove auger motor assembly. (see auger motor assembly removal).
3. Disconnect leads from capacitor, remove hex screw and remove capacitor.
4. Reverse procedure to reassemble.

Evaporator Fan Motor Assembly

1. Remove all freezer shelving.
2. Remove lower evaporator cover hex head screws.
3. Remove evaporator cover.
4. Disconnect evaporator fan wiring and ground from motor.
5. Raise top freezer cover about two inches.
6. Grasp and pull complete evaporator motor assembly toward you.
7. Remove assembly from freezer.

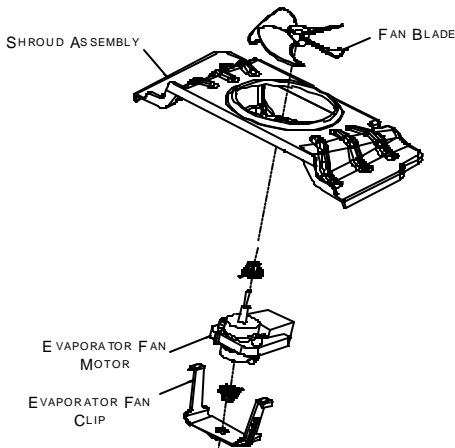

Evaporator Fan Motor and Fan Blade

1. Remove evaporator fan motor assembly (see evaporator fan motor assembly removal).
2. Remove evaporator fan blade by pulling blade off evaporator fan shaft.
3. Remove fan motor by squeezing motor retainer clips together to release retainer.
4. Remove retainer and slide motor out.
5. Reverse procedure to reassemble. Evaporator fan blade should be pushed down on shaft until it is seated.

Evaporator Removal

NOTE: Reclaim refrigerant per instructions in "Service Procedures" before attempting evaporator removal. To avoid system contamination, do not leave system open for more than 10 minutes.

1. Remove all freezer shelving.
2. Remove lower evaporator cover hex head screws.
3. Remove evaporator cover.
4. Remove defrost thermostat and defrost heater from coil (see disassembly instructions for both).
5. Release evaporator coil from clips by pulling coil off of clips.
6. Unsweat evaporator coil after completing reclaiming procedures found in Service Procedures section of this manual.
7. Reverse procedure to reassemble.

Defrost Terminator (Thermostat)

1. Remove all freezer shelving.
2. Remove lower evaporator cover hex head screws.
3. Remove evaporator cover.
4. Disconnect orange lead from defrost heater.
5. Cut Brown lead close to defrost terminator.
6. Unclip defrost terminator from evaporator coil.
7. Replace terminator and use wire nut(s) included in defrost terminator kit.
8. Reverse procedure to reassemble.

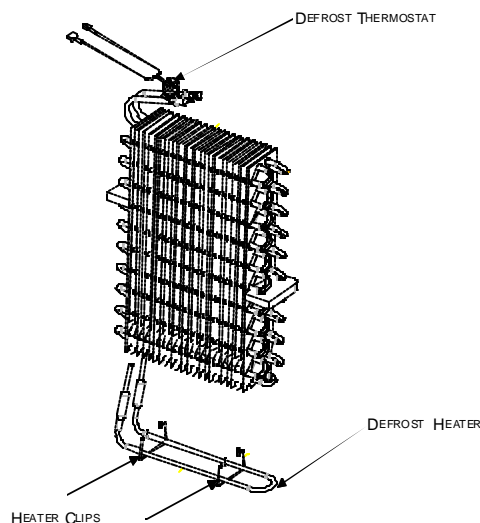

Defrost Heater

1. Remove all freezer shelving..
2. Remove lower evaporator cover hex head screws..
3. Remove evaporator cover.

Disassembly Procedures



WARNING

To avoid risk of electrical shock, personal injury, or death, disconnect electrical power source to unit, unless test procedures require power to be connected. Discharge capacitor through a resistor before attempting to service. Ensure all ground wires are connected before certifying unit as repaired and/or operational.

4. Grasp evaporator by left side to release coil from retainer clips.
5. Turn Evaporator slightly to expose heater leads.
6. Disconnect heater leads from harness.
7. Release heater clips holding heater to evaporator coil.
8. Remove heater.
9. Reverse procedure to reassemble.

Ice Maker Removal

1. Remove auger ice bucket and fast freeze shelf.
2. Disconnect ice maker harness from rear bulkhead.
3. Remove front two screws from left ice bucket rail.
4. Remove screws supporting ice maker from side bulkhead.
5. Remove ice maker.
6. Reverse procedure to reassemble.

NOTE: Make sure to get fill tube inserted in to fill cup fully when reassembling

Machine Compartment

Water Valves

1. Remove water valve cover plate on left side of machine compartment.
2. Disconnect wiring from water valve, reference color of connector to correct solenoid.
3. Disconnect water tubing from water valves, reference or mark tubing to ensure correct hookup upon reassemble.
4. Remove hex screw attaching valve to water valve cover plate.
5. Reverse procedure to reassemble.

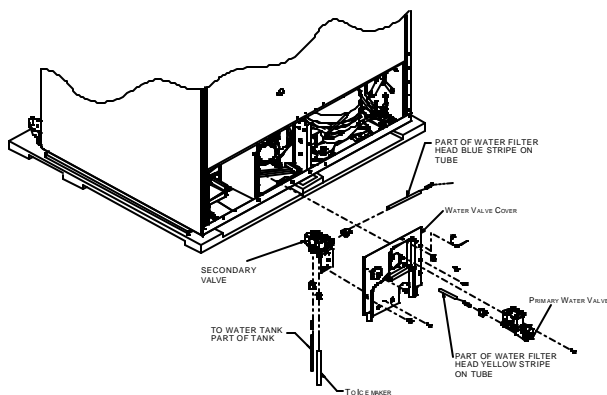

Condenser Fan Motor and Blade

1. Remove machine compartment hex screws.
2. Remove cover

3. Disconnect wiring harness connector from condenser motor.
4. Remove hex screws from mounting brackets attached to motor.
5. Remove motor and fan blade out the rear of shroud.
6. Remove the retainer nut to remove fan blade.
7. Reverse procedure to reassemble.

Compressor

1. Remove machine compartment hex screws.
2. Remove cover.
3. Remove bale strap which retains overload/relay/capacitor.
4. Pull overload/relay/capacitor assembly off of compressor terminals.
5. Disconnect ground wires attached to compressor.
6. Follow reclaiming procedures in Service Procedures section of this manual.
7. Remove drier.
8. Unbrazed low and high pressure lines at compressor.
9. Remove compressor mounting bolts.
10. Lift compressor out of unit.

NOTE: Install new drier and compressor per instructions in "Service Procedures." Evacuate and recharge sealed system per instructions in "Service Procedures."

Condensate Drain Tube

1. Remove machine compartment hex screws.
2. Remove cover.
3. Locate and remove hex screw holding drain tube in place.
4. Remove drain tube by pulling down on drain tube.
5. Reverse procedure to reassemble

Condensate Drain Pan

NOTE: Condensate drip pan may spill when steps 1 thru 4 are performed. Have a towel ready to mop up spillage.

1. Remove machine compartment and water valve cover hex screws.
2. Remove covers
3. Remove screws holding condenser shroud to base pan.
4. Raise rear of unit up about three inches and block up.
5. Remove two rear torx head screws holding rear of basepan to cabinet located under basepan.

Disassembly Procedures



WARNING

To avoid risk of electrical shock, personal injury, or death, disconnect electrical power source to unit, unless test procedures require power to be connected. Discharge capacitor through a resistor before attempting to service. Ensure all ground wires are connected before certifying unit as repaired and/or operational.

6. Lower cabinet back to floor after removing blocks.
7. Raise cabinet off of basepan enough to allow removal of condenser shroud, disconnect any wiring attached to shroud to ease removal of shroud.
8. After shroud is removed bend copper tubing up out of condensate pan to allow removal of condensate pan.
9. Reverse procedure to reassemble.

Overload/Relay

1. Remove machine compartment hex screws.
2. Discharge capacitor (if unit is so equipped) through a 10.000-ohm resistor.
3. Using fingers and standard screwdriver, press and pry bale strap off the overload/relay/capacitor assembly.
4. Reverse procedure to reassemble.

Condenser Removal

NOTE: Condenser is removed by laying unit on it's back and requires at least two people to do this procedure.

1. Remove machine compartment hex screws.
2. Remove cover.
3. Remove condenser fan motor and shroud.
4. Disconnect harness plug connecting machine compartment to cabinet.
5. Follow reclaiming procedures in Service Procedures section of this manual.
6. Remove drier and unbrazed tubing connecting machine compartment to cabinet.
7. Disconnect all cabinet wiring from machine tray.
8. With the help of second person lay unit on back on raised surface.
9. Remove four torx head screws holding basepan to cabinet.
10. Lift and remove basepan to access condenser coil.
11. Unbrazed condenser coil from connecting tubing.
12. Remove condenser coil by unsnapping it from retainers in basepan.
13. Reverse procedure to reassemble.

Bottom of Cabinet

Front Leveling Rollers

1. Remove toe grill and hinge caps.
2. Raise and block unit up three inches off of floor.
3. Screw front leveler bolts until they are loose from

leveling roller.

4. Slide leveling roller out rear of slot to remove roller.
5. Reverse procedure to reassemble.

Rear Leveling Rollers

1. Remove machine compartment and water valve cover hex screws.
2. Remove covers.
3. Tilt unit forward lifting rear of unit up about three inches.
4. Block unit up to keep weight off of rear leveling rollers.
5. Un screw leveling bolts from rear leveling rollers.
6. Push the leveling roller out the slots in the bottom of the unit.
7. Reverse procedure to reassemble.

Cabinet Doors

Door Gaskets

1. Grasp gasket in upper corners and pull gasket out of dart retainer.
2. When reinstalling door gaskets start at corners pushing dart edge into retainer and make sure to seat gasket flush to door.

Dispenser Facade (Messenger model)

1. Remove drip tray by pulling it straight out from door.
2. Remove two hex screws at the bottom of facade that were hidden by drip tray.
3. Push down on facade to release retainer clips.
4. Remove facade and disconnect ten pin connector and two pin speaker connector from display board.
5. Reverse procedure to reassemble.

Disassembly Procedures



WARNING

To avoid risk of electrical shock, personal injury, or death, disconnect electrical power source to unit, unless test procedures require power to be connected. Discharge capacitor through a resistor before attempting to service. Ensure all ground wires are connected before certifying unit as repaired and/or operational.

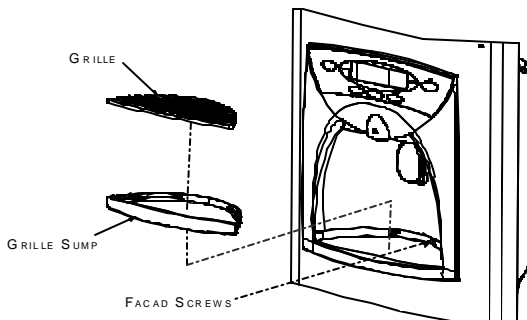

Dispenser Ice Chute Door

1. Remove dispenser facade (see dispenser facade removal)
2. Remove ice chute assembly (see D/C solenoid removal)
3. After ice chute assembly is removed unsnap ice chute dispenser door from assembly.
4. Retain spring if good, replace if bad.
5. Remove rubber seal from door and replace if bad.
6. Reverse procedure to reassemble.

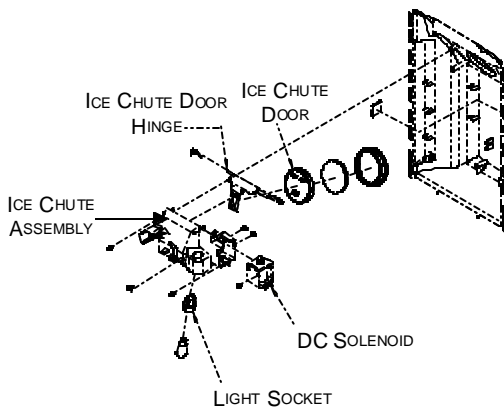

Dispenser Light Socket

1. Remove dispenser facade (see dispenser facade removal)
2. Remove light bulb.
3. Disconnect wires to socket assembly.
4. Squeeze tabs located by terminals to release socket.
5. Reverse procedure to reassemble.

Dispenser D/C Solenoid

1. Remove dispenser facade (see dispenser facade removal)
2. Remove dispenser water tube clip.
3. Remove water tube from DC assembly collar.

4. Remove wires from dispenser light socket.
5. Disconnect ground wire from solenoid assembly.
6. Disconnect wires from D/C solenoid.
7. Remove screws holding D/C solenoid and ice chute assembly.
8. Remove complete assembly.
9. Rotate to backside and remove screws holding D/C solenoid to ice chute assembly.
10. Lift ice chute door to release plunger from retainer.
11. Slide D/C solenoid out of the side of ice chute assembly.
12. Reverse procedure to reassemble.

Dispenser Water Tube

1. Remove toe grill and left hinge cap to expose dispenser water line coupler.
2. Disconnect water line coupler.
3. Remove compression nut and sleeve from door side of coupler.
4. Remove dispenser facade (see dispenser facade removal).
5. Remove holding clip from water line in cavity.
6. Pull water tube up from conduit in cavity to remove water tube.
7. Reverse procedure to reassemble.

High Voltage Board (Messenger Model)

1. Remove dispenser facade (see dispenser facade removal)
2. Disconnect high voltage and low voltage harness from high voltage board mounted on back wall of cavity.
3. Remove screws holding high voltage board to cavity.
4. Reverse procedure to reassemble.

Ice 'N Water Systems

Troubleshooting of 5 button electronic Ice 'N Water dispenser

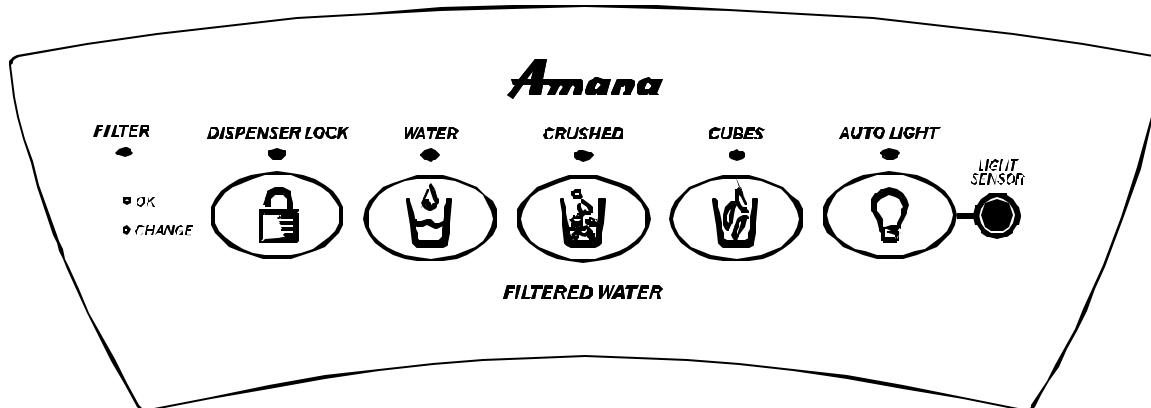

Dispenser Operation

Select WATER, CRUSHED or CUBED mode by pushing the button on the dispenser panel. A green indicator light above the button indicates the current selection. Selection mode cannot be changed from CRUSHED to CUBED or from CUBED to CRUSHED while ice dispenser is in operation.

Dispenser Light

Light activates at full power when dispensing ice or water. A sensor activates light at half-power when light level around refrigerator is low. Activate or deactivate sensor by pushing AUTO LIGHT button located on control façade. Green light above AUTO LIGHT button indicates sensor is active.

Dispenser Lock

Prevents operation of water and ice dispensers. To activate or deactivate lock, press and hold DISPENSER LOCK button for 3 seconds. Green light above button indicates dispenser lock.

Automatic Lock Out

Shuts down both ice and water mechanisms of dispenser when either mechanism has run continuously for 5 minutes. To return power to dispenser, press and hold DISPENSER LOCK for 3 seconds. Auger motor shuts off automatically after 3 minutes of continuous operation. After about 3 minutes in shut-off state, auger motor resets automatically.

Filter Status Light

This feature reminds users to replace water filter after 6 months have passed or after 500 gallons of water are filtered, whichever happens first.

NOTE: Filter status light turns red after 6 months have passed or after 500 gallons of water are dispensed, even if bypass is installed and unit is used without filter cartridge.

Green light indicates filter in good condition. Red light indicates filter replacement needed.

The filter monitor works by keeping track of time:

- Six months is approximately 16 million seconds.
- The refrigerator's water system requires about 53,000 seconds to pass 500 gallons of water.
- Each second that water is dispensed counts as 1.20 ounces of water.
- An additional 3.20 ounces of water is counted every 30 minutes. This attempts to account for ice usage.

Filter Status Light Reset

Once filter light turns red, it remains red until reset. To reset filter indicator, press both DISPENSER LOCK and WATER pushbuttons simultaneously and hold for 4 seconds. Make sure green light flashes 3 times when indicator resets.

Ice 'N Water Systems

Table A: Harness 10-pin Connector Configuration

Pin	Color	Signal
1	GY	Ice Door Chute Solenoid
2	BR	Dispenser Light
3	BU	Crushed
4	OR	Cubed
5	BK	Line Out
6	RD	Main Actuator
7	YL	Water Valve
8	VT	Line In
9		
10	WH	Neutral

Note: All voltage measurements are referenced to line neutral or pin 10 (WH wire) of 10-pin connector.

Symptom	Possible Cause	Test Procedure	Repair
No LED lit	Switch failure in freezer door.	With unit powered, open freezer door. Press freezer door switch in. If freezer light does not turn off, switch is defective.	Replace switch.
	Incorrect harness wiring.	Verify wire color on 10-pin connector. Refer to Table A.	Correct wiring.
	No power to the PCB.	With unit powered, measure voltage between (WH wire) and (VT wire) pin 8 of 10-pin connector. Meter should read 120VAC.	Replace PCB if meter reads 120VAC.
No dispenser light when Main or Water dispenser switch is pressed in Water, Crushed or Cubed mode.	No continuity.	Disconnect power. Measure continuity between (BR wire) pin 2 of 10-pin connector and dispenser lamp terminal.	Repair open connection.
	Failed light bulb or PCB.	With unit powered, press the Main dispenser switch. Measure voltage on pin 2 (BR wire) of 10-pin connector. Voltage should read 120 VAC.	Replace dispenser light bulb if voltage reads 120 VAC.
Dispenser light is on without pressing the Main or Water dispenser switch in Water, Crushed or Cubed mode.	Failed Main dispenser switch (failed short)	Disconnect power. Remove both leads from the switch and measure resistance across switch terminals. Resistance should read less than 1 Ω in this position and higher than 10 M Ω when switch is open.	Replace switch
	Failed PCB	With PCB powered, measure voltage on pin 3 (BU wire) of 10-pin connector. Voltage should read 0 VAC.	Replace PCB.
Water LED is illuminated but does not dispense water when Main dispenser switch is pressed.	Failed Main dispenser switch (failed open)	Disconnect power. Remove both leads from the switch and measure resistance across switch terminals. Resistance should read less than 1 Ω in this position and higher than 10 M Ω when switch is open.	Replace switch.
	No continuity	Disconnect power. Remove the cover of freezer door hinge located on top of the unit and disconnect the connectors. Check OR wire (pin 4 of 10-pin connector) for continuity.	Repair open connection.
Water starts to dispense as soon as Water mode is selected without pressing the Main dispenser switch	Failed Main dispenser switch (failed short)	Disconnect power. Remove both leads from the switch and measure resistance across switch terminals. Resistance should read less than 1 Ω in this position and higher than 10 M Ω when switch is open.	Replace switch.
	Failed PCB	With PCB powered, measure voltage on pin 7 (YL wire) of 10-pin connector. Voltage should read 0 VAC.	Replace PCB.

Ice 'N Water Systems

Symptom	Possible Cause	Test Procedure	Repair
Cubed LED is illuminated but does not dispense cubed ice when Main dispenser switch is pressed.	Failed Main dispenser switch (failed open)	Disconnect power. Remove both leads from the switch and measure resistance across switch terminals. Resistance should read less than 1 Ω in this position and higher than 10 M Ω when switch is open.	Replace switch.
	No continuity	Disconnect power. Remove the cover of freezer door hinge located on top of the unit and disconnect the connectors. Check OR wire (pin 4 of 10-pin connector) for continuity.	Repair open connection.
	Failed auger motor or PCB.	With PCB powered, press the Main dispenser switch. Measure voltage on pin 4 (OR wire) of 10-pin connector. Voltage should read 120VAC.	Replace auger motor if voltage reads 120VAC. If not, replace PCB.
Cubed ice starts to dispense as soon as Cubed mode is selected without pressing the Main dispenser switch	Failed Main dispenser switch (failed short)	Disconnect power. Remove both leads from the switch and measure resistance across switch terminals. Resistance should read higher than 10 M Ω when switch is open and less than 1 Ω when switch is closed.	Replace switch
	Failed PCB	With PCB powered, measure voltage on pin 4 (OR wire) of 10-pin connector. Voltage should read 0 VAC.	Replace PCB.
Dispenser operates continuously even when Dispenser Lock mode is activated.	Failed PCB	With PCB powered, measure voltage on pin 5 (BK wire) of 10-pin connector. Voltage should read 0 VAC.	Replace PCB
Auto Light mode does not operate.	Failed PCB	With PCB powered and Auto Light activated, cover the light sensor. Measure voltage on pin 2 (BR wire) of 10-pin connector. Voltage should read 1/2 the AC power supply (120 VAC).	Replace PCB.
Ice or Water dispenser mechanism runs continuously.	Failed PCB	With PCB powered, measure voltage on pin 5 (BK wire) of 10-pin connector. Voltage should read 0 VAC.	Replace PCB.
Filter Status LED never changes to red.	Failed PCB	Verify with the user if unit has been unplugged for a long period. Demonstrate reset operation to customer.	Replace water filter and reset Filter Status. Replace PCB if problem continues. Customer education.
1. Auger motor operates in Cubed or Crushed mode but ice door chute never opens. 2. Auger motor operates in Cubed or Crushed mode but ice door chute never closes.	Failed solenoid	Disconnect power. Remove both leads from the solenoid and measure the resistance across solenoid terminals. Resistance should read 101.2 \pm 10%.	Replace solenoid.
	Failed PCB	Measure voltage on pin 1 (GY wire) of 10-pin connector. Voltage should read approximately 55VDC when ice chute door is open (solenoid energized) or 0VDC when closed (solenoid not energized).	Replace PCB.
No LED lit, Water dispenser operates, auger motor operates only in Cubed mode and ice chute door does not open or remains open.	Failed PCB		Replace PCB
No LED lit, Water dispenser operates, auger motor operates only in Cubed mode and dispenser light is on continuously.	Failed PCB		Replace PCB
Neither Water, Crushed or Cubed LED will not illuminate but Water, Crushed or Cubed mode operates properly when selected.	Failed PCB		Replace PCB

Ice 'N Water Systems

Symptom	Possible Cause	Test Procedure	Repair
Crushed LED is illuminated but does not dispense crushed ice when Main dispenser switch is pressed.	Failed Main dispenser switch (failed open)	Disconnect power. Remove both leads from the switch and measure resistance across switch terminals. Resistance should read less than 1 Ω in this position and higher than 10 M Ω when switch is open.	Replace switch.
	No continuity	Disconnect power. Remove the cover of freezer door hinge located on top of the unit and disconnect the connectors. Check BU wire (pin 3 of 10-pin connector) for continuity.	Repair open connection.
	Failed auger motor or PCB.	With PCB powered, press the Main dispenser switch. Measure voltage on pin 3 (BU wire) of 10-pin connector. Voltage should read 120VAC.	Replace auger motor if voltage reads 120VAC. If not, replace PCB.
Crushed ice starts to dispense as soon as Crushed mode is selected without pressing the Main dispenser switch.	Failed Main dispenser switch (failed short)	Disconnect power. Remove both leads from the switch and measure resistance across switch terminals. Resistance should read less than 1 Ω in this position and higher than 10 M Ω when switch is open.	Replace switch
	Failed PCB	With PCB powered, measure voltage on pin 3 (BU wire) of 10-pin connector. Voltage should read 0 VAC.	Replace PCB.

Seconds to dispense 10 oz. water

Supply pressure	35 psig	45 psig	55 psig	75 psig
Filter model Bypass installed	9.0	8.0	7.0	6.0
Filter model New filter installed	11.0	10.0	8.0	7.0

Amana specifies a minimum supply pressure of 35 psig for water filter units. Minimum pressure requirement ensures that water valves close and sufficient water volume is available to fill icemaker. Proper fill is 140 cc. of water in 7.5 seconds. Failure of water valves to close because of low pressure will result in fill-tube freeze-up or dripping at cavity.

Ice 'N Water Systems

Troubleshooting of Amana Messenger Ice 'N Water dispenser

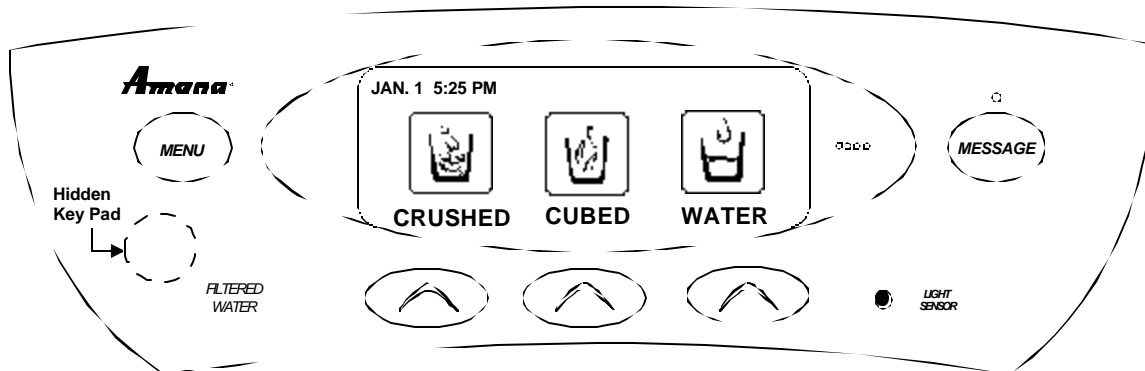

Power Board: This PCB is attached to the freezer door cavity. A wire harness from the door hinge runs through the door and terminates in the cavity. The power board receives its power from this harness. This PCB has 4 relays and a triac onboard that control the water valve, the night-light, the ice chute solenoid as well as the auger motor for crushed and cubed ice.

Control Board: This PCB is attached to the dispenser façade by 2 screws. All of the LCD Modules graphic information, message center voice information and the microcontroller logic are onboard. There is also a breakaway PCB with a microphone for the message center and a light sensor for automatic night-light operation. The breakaway PCB attaches to the façade by 2 snaps and a couple of alignment rails. This PCB sends command signals to the power board to energize the relays and triac on the power board. The control board receives its power from the power board through the 10-pin jumper harness. The voltage signals on this board do not exceed 5 VDC when the refrigerator is operating.

LCD Module: This PCB is attached to the dispenser façade insert-molded, clear polycarbonate lens by 4 screws. It receives its power and information from a 20-pin ribbon cable that attaches to the control board. It is a 288x96 FSTN liquid crystal graphic display utilizing 2 TAB drivers. It also has 7 ultra-bright blue colored LEDs positioned along the top of the module that together form a backlight so that graphic information is easily read in low ambient light conditions.

Keyboard: This component has 6 switches and is attached to the front of the façade. The switch circuits attach to the control PCB via a tail through the back of the façade.

Speaker: This component is attached to the ice chute extension by sliding into a slot. A speaker cap is pushed into place to hold the speaker in place. It couples the speaker energy into the surrounding plastic and prevents the speaker from rattling during high volume playback. *The speaker will distort at high volume message playback levels but it should not rattle.* The speaker wires attach to the control board just under the keyboard connector.

Ice 'N Water Systems

Freezer Door Harness connection to the power board:

Pin	Color	Power Board Graphic Marking	Signal and State Definition		
1	WH	NEU	LINE NEUTRAL INPUT (TOP PIN OF LARGE CONNECTOR)	0 VAC CONSTANT	
2	N/C		NO CONNECTION		
3	RD/WH	FF	FRESH FOOD DOOR INPUT	DOOR OPEN 0 VAC	DOOR CLOSED 115 VAC
4	VT	FZ	FREEZER DOOR INPUT	DOOR OPEN 115 VAC	DOOR CLOSED 0 VAC
5	RD	L1	LINE POWER INPUT	115 VAC CONSTANT	
6	YL	WAT	WATER SOLENOID OUTPUT	VALVE ON 115 VAC	VALVE OFF 0 VAC
7	OR	CUB	CUBED ICE MOTOR DRIVE	CUBE WINDING ON 115 VAC	CUBE WINDING OFF 0 VAC
8	BU	CSH	CRUSHED ICE MOTOR DRIVE	CRUSHED WINDING ON 115 VAC	CRUSHED WINDING OFF 0 VAC
9	GY	ICE	ICE CHUTE SOLENOID OUTPUT	SOLENOID ENERGIZED 115 VAC	SOLENOID NOT ENERGIZED 0 VAC
10	BR	LIT	NIGHT-LIGHT OUTPUT (BOTTOM PIN OF LARGE CONNECTOR)	NIGHT-LIGHT OFF 0 VAC	HALF-BRIGHT LEVEL 65 VAC OR FULL BRIGHT LEVEL 115 VAC

Jumper Harness from the power board header J1 to the control board header J1:

Pin	Color	Signal
1	GY	NIGHT-LIGHT (0, 2 or 4 VDC) (TOP PIN OF SMALL CONNECTOR ON POWER BOARD)
2	BR	Door status input (both doors open or closed – 2.0 VDC, FZ door open – 5VDC, FF door open - < 0.5 VDC)
3	VT	Reference (2.0 – 2.5 VDC continuous)
4	OR	ICE CHUTE (5VDC WHEN ENERGIZED)
5	BU	CRUSHED ICE (5VDC WHEN ENERGIZED)
6	RD	CUBED ICE (5VDC WHEN ENERGIZED)
7	YL	WATER (5VDC WHEN ENERGIZED)
8	WH	(5VDC CONSTANT)
9	N/C	NO CONNECTION
10	BK	GROUND (BOTTOM PIN OF SMALL CONNECTOR)

Dispenser Switch Harness

Pin	Color	Signal
1	BU	DISPENSER SWITCH
2	RD	WATER SWITCH
3		N/C
4	BK	COMMON

Keyboard switch test:

PRESS PAD NAME	MEASURE 100 – 500 OHMS ACROSS TRACES
MESSAGE	2 AND 4
MENU	3 AND 4
LEFT	1 AND 3
CENTER	1 AND 4
RIGHT	1 AND 5
HIDDEN	2 AND 5
MESSAGE LED CIRCUIT	7 TO 8 (< 2 K OHMS) 8 TO 7 (INFINITE OHMS)

Ice 'N Water Systems

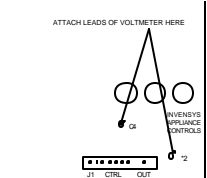
Symptom	Possible Cause	Test Procedure	Repair
Dead Control: No display No sound No dispensing	Open circuit in the L1 RED wire in the freezer door harness.	Unplug the refrigerator. Remove the large 10-pin connector from the power board. Power up the refrigerator. Take line voltage reading between RED wire on pin 5 (L1) on the connector across to the unit chassis. The reading must be <u>line voltage level</u> .	If the correct voltage is not measured, then locate source of the open on L1 or the ground wire/connection to the wall outlet and repair/replace as necessary. If voltage reading is ok, then go to the frame below.
	Open circuit in the neutral WHITE wire in the freezer door harness.	Perform test above first, then if it passes, take line voltage reading between RED wire pin 5 (L1) on the connector across to WHITE wire pin 1 (NEU). The reading must be line voltage level.	If the correct voltage is not measured, then locate source of the open and repair/replace as necessary. If break in the wire is not accessible, then replace the door. If voltage reading is ok, then go to the frame below.
	Failed power board	Unplug the refrigerator. Remove the small 10-pin connector at the bottom of the power board from the power board. Power up the refrigerator. Take a voltage reading between pin 8 and pin 10 at the very bottom of the header on the PCB. The reading must be 5.0 VDC +/- 0.25 VDC.	If the correct voltage is not measured, then replace the power board. If voltage reading is ok, then go to the frame below.
	Failed control board or LCD Module.	Place one Probe left of the C4 graphic on the PCB. The other probe needs to be placed on the solder test point just right of J1 the 10 pin header. Control Board 	If the correct voltage is present, then replace the control board. If the correct voltage is not present, then disconnect the LCD Module tail at the control board and check the voltage again. Now if the correct voltage is present, replace the LCD Module. If the black and white jumper harness wires are not making good contact, then repair/replace the jumper harness wires, otherwise replace the control board.
Either ice or water never dispenses. Animation does not display when the switch is pressed.	<ol style="list-style-type: none"> Open wire on the dispenser harness Control board failure. Switch failure Mechanical failure of pushbutton or dispenser pad. 	<p>With the unit powered up, connect a voltmeter configured for DC volts:</p> <p>For a "no auger motor operation", check across pins 1 and 4 of the dispenser connector. For a "no water flow", check across pins 2 and 4 of the dispenser connector.</p> <p>When the switch is not pressed there should be 5.0 VDC. When the switch is pressed, there should be 0 VDC.</p> <p>Measure voltage without pressing the switch. The meter should measure 5.0 VDC.</p>	<p>If there is 0 VDC, then disconnect the dispenser harness and read the meter again.</p> <p>If there is still 0 VDC then replace the control board.</p> <p>Otherwise if the meter reads 5.0 VDC, then close the switch. The meter must read 0VDC. If it does not, then test the dispenser harness connections, water and dispenser switch function and mechanical functioning of the pushbuttons.</p> <p>Repair or replace as needed.</p>
Water never dispenses. Animation displays when the switch is pressed.	Failed control board, power board, water valve or harness.	Setup voltmeter to read line voltage. Attach meter probes to Power board J2 pins 1 (WH) and 6 (YL). When the system is powered up and the dispenser switch is open, <15 VAC must be read. When the switch is closed, line voltage must be read.	<p>If the proper voltages are read, then the problem is in the wiring back to the water valve or one of the water valves.</p> <p>If the proper voltages are not read, then setup voltmeter to read 5.0 VDC. Measure voltage on the power board from J1 pins 7 to 10. 5 VDC must be read when the switch is closed.</p> <p>If the proper voltage is read, then replace the power board otherwise check the harness and replace either the harness or the control board.</p>
Ice never dispenses. Animation displays when switch is closed.	Failed control board, power board, auger motor or harness.	Setup voltmeter to read line voltage. Attach meter probes to Power board J2 pins 1 (WH) and 7 (OR) for cubed ice or 8 (BL) for crushed ice direction. When the system is powered up and the dispenser switch is open, <15 VAC must be read. When the switch is closed, line voltage must be read.	<p>If the proper voltages are read, then the problem is in the wiring back to the auger motor or the auger motor itself.</p> <p>If the proper voltages are not read, then setup voltmeter to read 5VDC. Measure voltage on the power board from J1 pins 6 (RD) for cubed or 5 (BU) for crushed and pin 10 (BK). 5 VDC must be read when the switch is closed.</p> <p>If the proper voltage is read, then replace the power board otherwise check the harness and replace either the harness or the control board.</p>

Ice 'N Water Systems

Symptom	Possible Cause	Test Procedure	Repair
Ice never dispenses. Animation displays when switch is closed.	Failed ice chute solenoid	Listen for auger motor operation while the switch is pressed. If the auger motor is operating, then check that the ice chute door is not mechanically stuck closed. If there is not a mechanical problem, then check for line voltage across the solenoid during operation. If line voltage is present then replace the solenoid. Otherwise, verify that there is line voltage on J2 of the power board pins 1 to 9 during operation.	If line voltage is present, then repair/replace the wiring to the solenoid. Otherwise check for 5.0 VDC present at the power board J1 pins 4 to 10. If 5.0 VDC is present, then replace the power board. If no voltage is present, then check the same pins on J1 of the control board. If 5 VDC is present on the control board then repair/replace the harness, else replace the control board.
Auger motor continuously cycling on and off when dispenser button is not being pressed.	Motor is cycling on thermal overload. Switch is stuck closed or mechanical obstruction is forcing switch closure.	Set up meter to read 5 VDC. Check across pins 1 and 4 of the dispenser connector. Without pressing dispenser switch the voltage should be 5 VDC.	If the reading is 0 VDC, then the dispenser switch is closed in error. Troubleshoot the pad assembly and switch. Repair or replace as necessary. If voltage measures ok, then remove probe from pin 1 and check voltage at J1 pins 4 and 5. If 5 VDC is read at either point, then replace the control board otherwise replace the power board.
Water flowing continuously without pressing a dispensing button.	Water valve stuck open.	Open the freezer door.	If the water flow does not stop, then replace the water valve. Otherwise go to the frame below.
	Dispensing switch stuck closed	Set up meter to read 5 VDC. Check across pins 1 to 4 and 2 to 4 of the dispenser connector. Without pressing dispenser switch the voltage should be 5 VDC.	If either reading is 0 VDC, then the switch is closed in error. Troubleshoot the pad assembly or Front Fill button and switch. Repair or replace as necessary. If voltage measures ok, then remove probe from pin 1 and check voltage at J1 pin 7. If 5 VDC is read, then replace the control board otherwise replace the power board.
Cannot turn off the door alarm and the display says one of the doors is open all the time.	Failed or improperly adjusted door or the door switch.	Open the door signaled as being open. Manually close the door switch. Does the alarm stop? If so, then check the door adjustment. Otherwise go to the next frame below.	Adjust door, door switch or replace the door switch as needed to turn off the alarm.
	Failed wiring harness or connection to the power board.	Unplug the refrigerator. Remove the façade from the door. Disconnect the freezer door harness from the power board. To test the freezer door connections, attach the voltmeter probes to J2, VT wire (pin 4) and WH (pin 10) on the harness. Set up the meter for line voltage AC type. Place the meter so that it is not held or touching any metal. Power up the refrigerator. There must be line voltage across the meter when the door is closed and <15 VAC when the door is open. To test the refrigerator door connections, use the same procedure as for the freezer door test above except attach the voltmeter probes to J2, RD/WH wire (pin 3) and WH (pin 10) on the harness.	If the voltage readings are incorrect, then power down the refrigerator and replace the power board. Otherwise power down the refrigerator. Attach the control board to the unit. Move the probes to J1 pins 10 and 2 on the control board. Repeat the last test. If the voltage readings are incorrect, then replace the jumper harness, otherwise replace the control board.

Ice 'N Water Systems

Symptom	Possible Cause	Test Procedure	Repair
Dispenser light never turns on.	The bulb is not screwed in tight in the socket.	Check to see if the bulb is tight in the socket.	Screw the bulb in tight.
	The bulb filament has opened.	Check the bulb for continuity.	Replace the bulb.
	The bulb socket contacts are not contacting the bulb metal surface.	Test for the presence of line voltage across the terminals on the socket while dispensing.	Repair/replace the bulb socket.
No prerecorded sounds or messages can be heard.	The volume is set too low.	Press the MESSAGE PAD. Record and play back a message. Adjust the volume until it can be heard.	Done.
	A speaker wire is not attached or is broken.	Measure the resistance of the speaker and wire harness. It should be 8 +/- 1 Ohms.	If the reading is within range, then replace the control board. Otherwise, replace the speaker or repair the wire connection.
No message LED	Failed keyboard.	Set up meter to read 5 VDC. Press the MESSAGE PAD. Record a message and press STOP button. The message LED should begin to flash. If it does not, then measure the voltage from pin 4 of the dispenser switch header J4 on the control board to R14 just above and to the right of the keyboard connector.	The voltage should be cycling between 5 and 0 VDC. If it does not, then replace the control board, otherwise replace the keyboard.
Prerecorded sounds are ok but cannot hear user messages at all.	Control board microphone malfunctioning	Press the MESSAGE PAD. Record and play back a message. Try adjusting the volume.	If user messages cannot be heard but prerecorded sounds can be heard, then replace the Control board.
Messages can be heard but there are no prerecorded sounds	The NO SOUND option has been set in the control.	From the dispenser screen press the MENU pad. For the SOUND Option select either TONE or VOICE and retest.	If it works, then done. If it fails, then verify the volume is turned up loud enough to hear. If it still fails then replace the control board.
Control not responding to keyboard pad presses	Keyboard tail not fully inserted into control board header.	Reinstall the keyboard tail into the control board and retest. If the control does not respond to keyboard pad presses then test the keyboard as defined above.	Replace the keyboard if it fails the test, otherwise replace the control board.
Night-Light is always on. Sometimes it is dim and sometimes it is bright.	The LIGHT option is configured ON.	When the LIGHT is ON, then in low light the light is on at ½ power and when there is a lot of ambient light, the light is on full power.	Done.
LCD Module is hard to read.	The LCD backlight has been turned off.	From the dispenser screen, press and hold the MENU pad for 3 seconds until the screen changes. Press the buttons under the arrow pads until TURN ON THE DISPLAY LIGHT is highlighted. Press the pad under SELECT to turn on the display light.	Done.
	The LCD Contrast is too low.	From the dispenser screen press MENU pad 3 times until SET AUDIO VOLUME appears in the display banner. Press SELECT pad to display the SET LCD CONTRAST screen. Press the up and down arrows until the desired contrast is achieved.	Done.
LCD backlight sometimes is dim, sometimes bright.	Automatic backlight level adjustment.	The LCD backlight has 3 separate levels; low, medium and high. When the room is dark the backlight automatically will be in the low state. In medium light level conditions the LCD backlight will be at a medium level. In bright rooms the LCD backlight level will be high.	No manual adjustment is available.
No LCD Graphics visible	Failed LCD Module or control board.	<ol style="list-style-type: none"> 1. Press the message pad to get into the message center. 2. Press the LEFT pad under the display to record a message. Speak into the microphone area for about 10 seconds. 3. Press the LEFT pad again to stop recording. Does the message begin to flash on and off? 4. Press the MESSAGE pad and then press and hold the CENTER pad under the display to begin playback of the message and begin increasing the volume of the playback. Can the recorded message be heard? 	If the answer to either of these questions is YES, then replace the LCD module. Otherwise replace the control board.

Ice 'N Water Systems

Troubleshooting of 3 button electronic Ice 'N Water dispenser

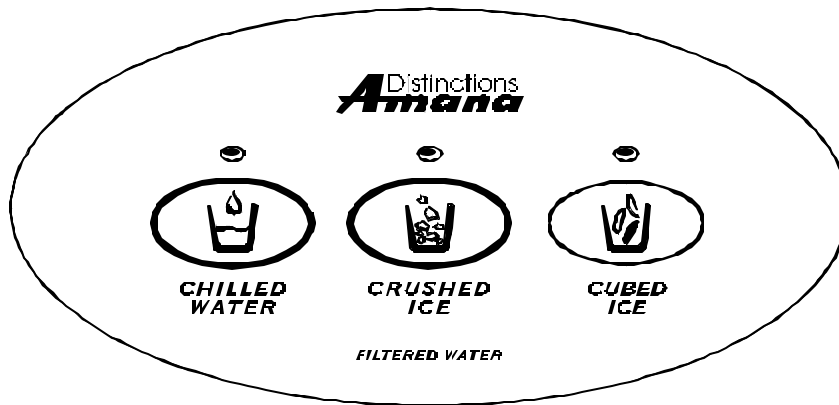

Dispenser Operation

Select WATER, CRUSHED or CUBED mode by pushing the button on the dispenser panel. A green indicator light above the button indicates the current selection.

Dispenser Light

Light activates at full power when dispensing ice or water.

Table A: Harness 9-pin Connector Configuration

Pin	Color	Signal
1	GY	Ice Door Chute Solenoid
2	BR	Dispenser Light
3	OR	Cubed
4	BU	Crushed
5	RD	Line
6	YL	Main Actuator
7	VT	Line In
8		
9	WH	Neutral

Note: All voltage measurements are referenced to line neutral or pin 9 (WH wire) of 9-pin connector

Ice 'N Water Systems

Symptom	Possible Cause	Test Procedure	Repair
No LED lit	Switch failure in freezer door.	With unit powered, open freezer door. Press freezer door switch in. If freezer light does not turn off, switch is defective.	Replace switch.
	Incorrect harness wiring.	Verify wire color on 9-pin connector. Refer to Table A.	Correct wiring.
	No power to the PCB.	With unit powered, measure voltage between pin 9 (WH wire) and pin 7 (VT wire) of 9-pin connector. Meter should read 120VAC.	Replace PCB if meter reads 120VAC.
No dispenser light when dispenser switch is pressed in Water, Crushed or Cubed mode.	No continuity.	Disconnect power. Measure continuity between pin 2 (BR wire) of 9-pin connector and dispenser lamp terminal.	Repair open connection.
	Failed light bulb or PCB.	With unit powered, press the dispenser switch. Measure voltage on pin 2 (BR wire) of 9-pin connector. Voltage should read 120VAC.	Replace dispenser light bulb. If not, replace PCB.
Dispenser light is on without pressing the dispenser switch in Water, Crushed or Cubed mode.	Failed dispenser switch (failed short)	Disconnect power. Remove both leads from the switch and measure resistance across switch terminals. Resistance should read less than 1 Ω in this position and higher than 10 M Ω when switch is open.	Replace switch.
	Failed PCB	With unit powered, measure voltage on pin 2 (BR wire) of 9-pin connector. Voltage should read 0VAC	Replace PCB.
Water LED is illuminated but does not dispense water when dispenser switch is pressed	Failed dispenser switch (failed open)	Disconnect power. Remove both leads from the switch and measure resistance across switch terminals. Resistance should read less than 1 Ω in this position and higher than 10 M Ω when switch is open.	Replace switch.
	No continuity	Disconnect power. Remove the cover of freezer door hinge located on top of the unit and disconnect the connectors. Check YL wire (pin 6 of 9-pin connector) for continuity.	Repair open connection.
	Failed water valve or PCB.	With PCB powered, press dispenser switch. Measure voltage on pin 6 (YL wire) of 9-pin connector. Voltage should read 120VAC.	Replace water valve if voltage reads 120VAC. If not, replace PCB.
Water starts to dispense as soon as Water mode is selected without pressing the dispenser switch	Failed dispenser switch (failed short)	Disconnect power. Remove both leads from the switch and measure resistance across switch terminals. Resistance should read less than 1 Ω in this position and higher than 10 M Ω when switch is open.	Replace switch.
	Failed PCB	With PCB powered, measure voltage on pin 6 (YL wire) of 9-pin connector. Voltage should read 0 VAC.	Replace PCB.
Crushed LED is illuminated but does not dispense crushed ice when dispenser switch is pressed.	Failed dispenser switch (failed open)	Disconnect power. Remove both leads from the switch and measure resistance across switch terminals. Resistance should read less than 1 Ω in this position and higher than 10 M Ω when switch is open.	Replace switch.
	No continuity	Disconnect power. Remove the cover of freezer door hinge located on top of the unit and disconnect the connectors. Check BU wire (pin 4 of 9-pin connector) for continuity.	Repair open connection.
	Failed auger motor or PCB.	With PCB powered, press dispenser switch. Measure voltage on pin 4 (BU wire) of 9-pin connector. Voltage should read 120VAC.	Replace auger motor if voltage reads 120VAC. If not, replace PCB.

Ice 'N Water Systems

Symptom	Possible Cause	Test Procedure	Repair
Crushed ice starts to dispense as soon as Crushed mode is selected without pressing the dispenser switch.	Failed dispenser switch (failed short)	Disconnect power. Remove both leads from the switch and measure resistance across switch terminals. Resistance should read less than 1 Ω in this position and higher than 10 M Ω when switch is open.	Replace switch
	Failed PCB	With PCB powered, measure voltage on pin 4 (BU wire) of 9-pin connector. Voltage should read 0 VAC.	Replace PCB.
Cubed LED is illuminated but does not dispense cubed ice when dispenser switch is pressed.	Failed dispenser switch (failed open)	Disconnect power. Remove both leads from the switch and measure resistance across switch terminals. Resistance should read less than 1 Ω in this position and higher than 10 M Ω when switch is open.	Replace switch.
	No continuity	Disconnect power. Remove the cover of freezer door hinge located on top of the unit and disconnect the connectors. Check OR wire (pin 3 of 9-pin connector) for continuity.	Repair open connection.
	Failed auger motor or PCB.	With PCB powered, press the dispenser switch. Measure voltage on pin 3 (OR wire) of 9-pin connector. Voltage should read 120VAC.	Replace auger motor if voltage reads 120VAC. If not, replace PCB.
Cubed ice starts to dispense as soon as Cubed mode is selected without pressing the dispenser switch	Failed dispenser switch (failed short)	Disconnect power. Remove both leads from the switch and measure resistance across switch terminals. Resistance should read higher than 10 M Ω when switch is open and less than 1 Ω when switch is closed.	Replace switch
	Failed PCB	With PCB powered, measure voltage on pin 3 (OR wire) of 9-pin connector. Voltage should read 0 VAC.	Replace PCB.
1. Auger motor operates in Cubed or Crushed mode but ice chute door never opens. 2. Auger motor operates in Cubed or Crushed mode but ice chute door never closes.	Failed solenoid	Disconnect power. Remove both leads from the solenoid and measure the resistance across solenoid terminals. Resistance should read – 101.2 ohms $\pm 10\%$	Replace solenoid.
	Failed PCB	Measure voltage on pin 1 (GY wire) of 9-pin connector. Voltage should read approximately 55VDC when ice chute door is open (solenoid energized) or 0 VDC when closed (solenoid not energized).	Replace PCB.
No LED lit, auger motor operates only in Cubed mode, and ice chute door never opens or never closes.	Failed PCB		Replace PCB
No LED lit, auger motor operates only in Cubed mode, and dispenser light never switches on or never switches off.	Failed PCB		Replace PCB
Neither Water, Crushed or Cubed LED will not illuminate but Water, Crushed or Cubed mode operates properly when selected.	Failed PCB		Replace PCB

Appendix A



Owner's Manual

Covering *Amana*® and *Amana Distinctions*® Models

Keep instructions for future reference.

Keep this manual and your sales receipt together in a safe place in case warranty service is required.

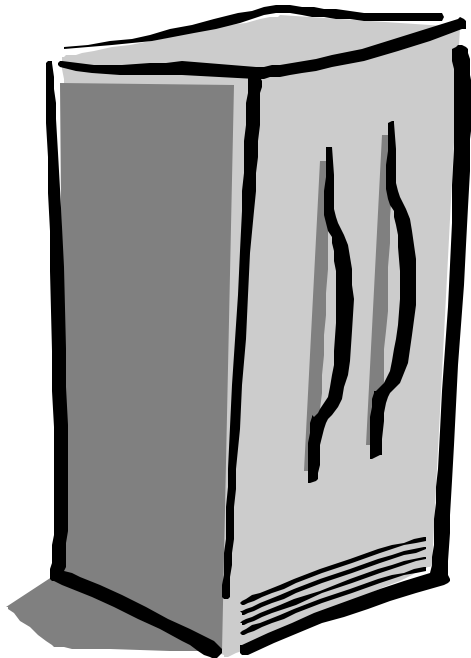

Contents

- Introduction 2
- Important Safety Information 3
- Installing Your Refrigerator 4
 - How to Remove the Doors and Hinges 4
 - How to Install the Handles 5
 - How to Connect the Water Supply 6
 - How to Level Your Refrigerator 7
 - How to Adjust the Temperature Controls 7
- About Your Filtration System 8
- Fresh Food Features 9
 - Interior Shelves 9
 - Door Storage 10
 - Drawers 11
- Freezer Features 12
 - Primary Features 12
 - Shelves 13
 - Door Storage 13
- Dispenser Features 14
 - Primary Features 14
 - Water Dispenser Operation 14
 - Control Features 15
- Hints and Care 16
 - How to Clean Your Unit 16
 - How to Remove and Replace Light Bulbs 17
- Trouble Shooting 18
- Water Filter Data 22
- Warranty 23

Side by Side Refrigerator

**Ordering parts and accessories?
Questions about your features?**

Please contact us with your model and serial number:

Consumer Affairs Department
Amana Appliances
2800 - 220th Trail
Amana, Iowa 52204
Ph# 1(800)843-0304
1(319)622-5511 outside U.S.A.
Internet: [http:// www.amana.com](http://www.amana.com)



As an Energy Star® Partner, Amana® has determined that this product* meets the Energy Star® guidelines for energy efficiency.



Thank you for buying an Amana refrigerator!

Please read this Owner's Manual thoroughly. This manual provides proper maintenance information.

Complete registration card and promptly return. If registration card is missing, call the Consumer Affairs Department.

Warranty service must be performed by an authorized servicer. Amana also recommends contacting an authorized servicer if service is required after warranty expires. To locate an authorized servicer, call **1-800-NAT-LSVC (1-800-628-5782)**, or call **1(319)622-5511** if outside the U.S.A. You may also contact us on the web at **www.amana.com**.

When contacting Amana, please provide the following information. Product information is on the serial plate, located on ceiling of fresh food section.

Model Number _____

'P' Number _____

Serial Number _____

Purchase Date _____

Dealer Name _____

Dealer Address _____

Dealer Phone _____

Asure™ Extended Service Plan

Amana offers long-term service protection for this new refrigerator. **Asure™ Extended Service Plan** is specially designed to supplement Amana's strong warranty. This plan covers parts, labor, and travel charges. Call **1(800)528-2682**, or contact us at **www.amana.com** for more information.

Before Calling Service...

If something seems unusual, please check "Trouble Shooting" section, which is designed to help you solve problems before calling service.

What if These Features are Different from Mine?

This book is intended to show the variety of features that are available in the product line. If your refrigerator does not have all the options that are shown, many of these options may be purchased by contacting the Consumer Affairs Department. See contact information on the cover of your manual.

Features at a Glance

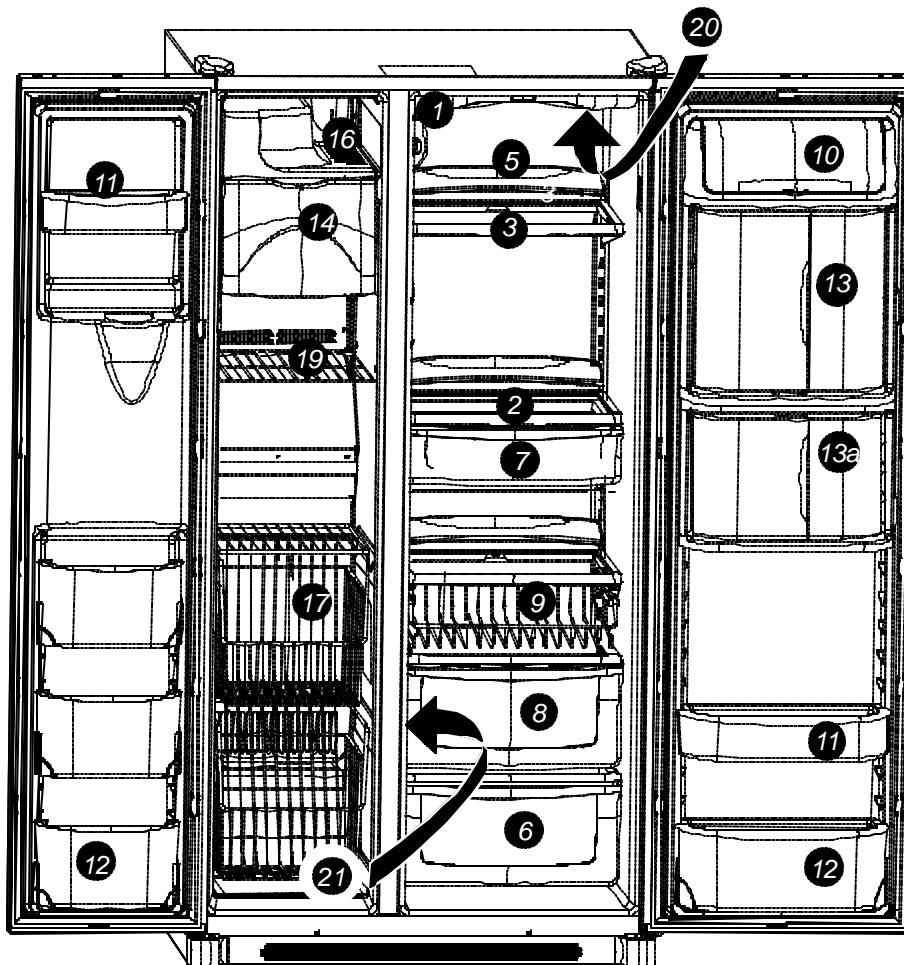

1. Temp Assure® controls (pg. 7)
2. Spill Saver™ shelf (pg. 9)
3. Spill Saver™ Easy Glide™ shelf (pg. 9)
4. Side Glide™ shelves—not shown (pg. 9)
5. Rear shelf extensions (pg. 9)
6. Deli/Crisper drawer (pg. 11)
7. Snack drawer (pg. 11)
8. Crisper drawer (pg. 11)
9. Beverage Organizer™ (pg. 11)
10. Dairy center (pg. 10)
11. Door buckets (pg. 10)
- 11a. Bucket grippers—not shown (pg. 10)
12. Tilt-out bucket (pg. 10)
13. Beverage Chiller™ (pg. 10)
- 13a. Mini-Beverage Chiller™ (pg. 10)
- 13b. Kid Zone™ —not shown (pg. 10)
14. Ice storage bin (pg. 12)
15. Ice maker—not shown (pg. 12)
16. Quick Chill Zone™ (pg. 12)
17. Stor-Mor® system (pg. 13)
18. Hanging wire shelf—not shown (pg. 13)
19. Fixed freezer shelf (pg. 13)
20. Water filter—not shown (pg. 8)
21. Air filter—not shown (see LCD dispenser instructions)
22. Lights—not shown (pg. 17)
 - Upper fresh food (pg. 17)
 - Lower fresh food (pg. 17)
 - Freezer (pg. 17)
 - Dispenser (pg. 17)

Important Safety Information

Recognize Safety Symbols, Words, Labels



DANGER

DANGER—Immediate hazards which **WILL** result in severe personal injury or death.



WARNING

WARNING—Hazards or unsafe practices which **COULD** result in severe personal injury or death.



CAUTION

CAUTION—Hazards or unsafe practices which **COULD** result in minor personal injury or product or property damage.

What You Need to Know about Safety Instructions

Warning and Important Safety Instructions appearing in this manual are not meant to cover all possible conditions and situations that may occur. Common sense, caution, and care must be exercised when installing, maintaining, or operating refrigerator. Always contact your dealer, distributor, service agent, or manufacturer about problems or conditions you do not understand.



WARNING

To reduce risk of fire, electric shock, serious injury, or death when using your refrigerator, follow these basic precautions, including the following:

1. Read all instructions before using refrigerator.
2. Observe all local codes and ordinances
3. Be sure to follow grounding instructions.
4. Check with a qualified electrician if you are not sure this appliance is properly grounded.
5. DO NOT ground to a gas line.
6. DO NOT ground to cold water pipe.
7. Refrigerator is designed to operate on a separate 103 to 126 volt, 15 amp., 60 cycle line. DO NOT modify plug on power cord. If plug does not fit electrical outlet, have proper outlet installed by a qualified electrician.
8. DO NOT use a two-prong adapter, extension cord or power strip.
9. DO NOT remove warning tag from power cord.
10. DO NOT tamper with refrigerator controls.
11. DO NOT service or replace any part of refrigerator unless specifically recommended in owner's manual or published user-repair instructions. DO NOT attempt service if instructions are not understood or if they are beyond personal skill level.
12. Always disconnect refrigerator from electrical supply before attempting any service. Disconnect power cord by grasping the plug, not the cord.
13. Install refrigerator according to Installation Instructions. All connections for water, electrical power, and grounding must comply with local codes and be made by licensed personnel when required.
14. Keep your refrigerator in good condition. Bumping or dropping refrigerator can damage unit or cause unit to malfunction or leak. If damage occurs, have refrigerator checked by qualified service technician.
15. Replace worn power cords and/or loose plugs.
16. Always read and follow manufacturer's storage and ideal environment instructions for items being stored in refrigerator.



WARNING

To reduce risk of injury or death, follow basic precautions, including the following:

Proper Disposal of Your Refrigerator

IMPORTANT: Child entrapment and suffocation are not problems of the past. Junked or abandoned refrigerators are still dangerous—even if they sit out for "just a few days". If you are getting rid of your old refrigerator, please follow the instructions below to help prevent accidents.

BEFORE YOU THROW AWAY YOUR OLD REFRIGERATOR OR FREEZER:

- Take off the doors.
- Leave the shelves in place so children may not easily climb inside.

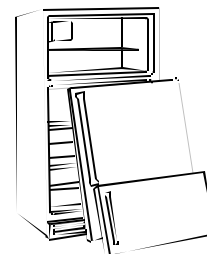

Save These Instructions

Installing Your Refrigerator

These instructions were provided to aid you in the installation of your unit. Amana cannot be responsible for improper installation.



How do I measure an opening to insure proper fit?

This refrigerator was designed to fit a 69" tall opening to allow for proper ventilation, leveling, and door adjustments.

Subflooring or floor coverings (i.e. carpet, tile, wood floors, rugs) may make your opening smaller than anticipated.

Some clearance may be gained by using the leveling procedure under *How to Level Your Refrigerator*.

IMPORTANT: If unit is to be installed into a recess where top of unit is completely covered, use dimensions from floor to top of hinge cap to verify proper clearance.

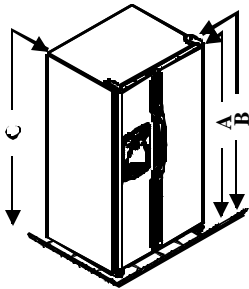

A = Floor to top of cabinet (68 3/4")

B = Floor to top of top hinge assembly (70 1/8")

C = Back of unit with 1/4" tilt to back (68 1/2")

How to Transport Your Unit

Follow these tips when moving the unit to final location:

- NEVER transport unit on its side. If an upright position is not possible, lay unit on its back. Allow unit to sit upright for approximately 30 minutes prior to plugging unit in to assure oil return to the compressor. Plugging unit in immediately may cause damage to internal parts.
- Use an appliance dolly when moving unit. ALWAYS truck unit from its side—NEVER from its front or back.
- Protect outside finish of unit during transport by wrapping cabinet in blankets or inserting padding between the unit and dolly.
- Secure unit to dolly firmly with straps or bungee cords. Thread straps through handles when possible. DO NOT overtighten. Overtightening restraints may dent or damage outside finish.

How to Select the Best Location

Observe these points when choosing the final location for your unit:

- DO NOT install refrigerator near oven, radiator, or other heat source. If not possible, shield unit with cabinet material.
- DO NOT install where temperature falls below 55°F (13°C). Malfunction may occur at this temperature.
- Make sure floor is level. If floor is not level, shim rear wheels of unit with a piece of plywood or other shim material.
- Allow a minimum of 1/2" clearance along top and back of unit for proper ventilation.
- To assure proper door closure, verify that the unit is leveled with a 1/4" tilt to the back.

How to Remove the Doors and Hinges

Some installations require door removal to get refrigerator to final location.

⚠ WARNING

To avoid electrical shock which can cause severe personal injury or death, observe the following:

- Disconnect power to refrigerator before removing doors. Connect power only after replacing doors.
- Green ground wire must be attached to top hinge while performing door removal and replacement.

⚠ CAUTION

To avoid damage to walls and flooring, protect soft vinyl or other flooring with cardboard, rugs, or other protective material.

1 Remove Toe Grille and Bottom Hinge Covers

- Open both doors 180°, or as wide as possible, to remove.

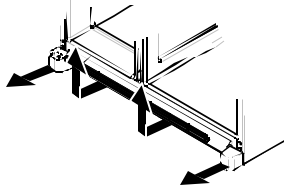

3 Remove top hinge cover by removing Phillips screw.

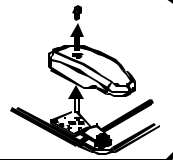

2 Unscrew union nut to detach water tube (dispensing models only)

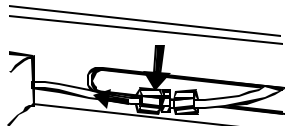

4 Unscrew 5/16" hex head screws from top hinges.

For dispensing models only

- DO NOT remove either green ground wire or wire connecting center screw.

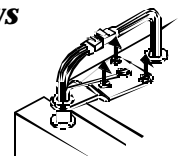

Installing Your Refrigerator

How to Remove the Doors and Hinges *continued*

5 Detach main wire connector harness. (dispensing models only)

- Use a flat blade screwdriver or fingernail to press junction point between two connectors to release.



Detach red wire harness (some models).

- Press tab on underside of connector to release.



6 Remove top hinges along with doors.

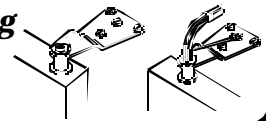

7 Remove bottom hinges with a 3/8" hex head driver.

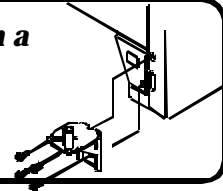

How to Replace the Doors

- To replace doors, follow the steps in **How to Remove the Doors and Hinges** in reverse order.

How to Install and Remove Handles

Handles are located within fresh food section of refrigerator. Trim, plugs, and accent pieces will be located within the literature assembly.

LCD and 5-button Dispenser Models (non-stainless steel)

1 Remove two 1/4" hex nut screws from bottom of refrigerator and freezer door.

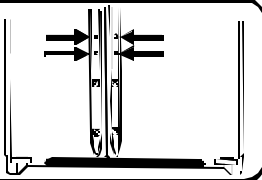

3 Insert screws removed in step 1 into screw holes at bottom of handle section.

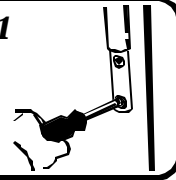

2 Align door handles with top and bottom sets of door clips, and slide down until screw holes on bottom of handles match with door screw holes.

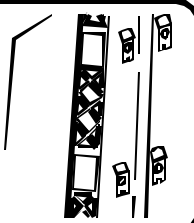

4 Snap trim over bottom portion of handles and retainers on bottom of door

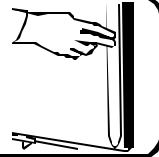

To remove after initial install..

- Follow steps 3 through 4 in reverse order.

NOTE: Fit may be tight. When removing handle, pull up and out.

Distinctions 3-button Dispenser Models

1 Remove four 1/4" hex nut screws from top and bottom of doors.

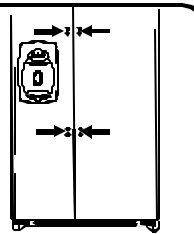

2 Align door handles with screw holes and insert screws removed in step 1.

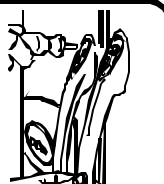

3 Snap colored handle trim over screw holes at top and bottom of handles.

- Snap in trim by inserting large round end first.



To remove after initial install..

Handles may need to be removed if transporting unit through tight spaces.

- Follow steps 2 and 3 in reverse order.

IMPORTANT: To avoid damage to handle, use a flat blade screwdriver edge wrapped in masking tape to remove colored handle trim.



Installing Your Refrigerator

How to Install the Handles *continued*

Stainless Steel Models

1 Loosen lower door clip on refrigerator door with $\frac{1}{4}$ " hex nut driver.

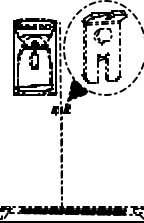

4 Insert $\frac{1}{4}$ " hex nut driver into predrilled hole at base of handle and tighten screw.

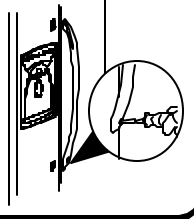

2 Locate predrilled hole at base of handle, and fit hollow end of handle over lower door clip.

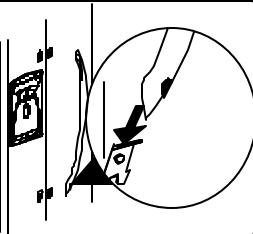

5 Insert screw plug into predrilled hole, as illustrated.

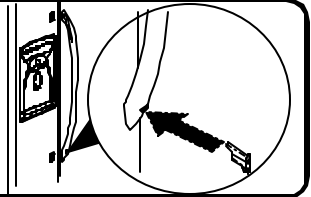

3 Fit other end of handle over upper door clip and slide up as far as possible.

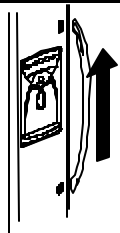

NOTE: If top of handle does not fit over top clip, loosen lower clip further until fit can be accomplished.

6 Repeat steps 2 through 5 to install freezer handle.

To remove after initial install...

- Follow steps 2 through 5 in reverse order.

IMPORTANT: To avoid damage to unit, use a flat blade screwdriver edge wrapped in masking tape to remove screw plugs.



How to Connect the Water Supply



WARNING

To avoid electrical shock which can cause severe personal injury or death, disconnect power to refrigerator before connecting water supply. After connecting water supply, connect power.



CAUTION

To avoid property damage, observe the following:

- Consult a plumber to connect copper tubing to household plumbing to assure compliance with local codes and ordinances.
- Confirm water pressure to water valve is between 20 and 100 pounds per square inch. If water filter is installed, water pressure to water valve must be a minimum of 35 pounds per square inch.
- DO NOT use a self-piercing, or $\frac{3}{16}$ " (4.8 mm) saddle valve. Both reduce water flow, become clogged with time, and may cause leaks if repair is attempted.
- Tighten nuts by hand to prevent cross threading. Finish tightening nuts with pliers and wrenches. Do not overtighten.
- Wait 24 hours before placing unit into final position to check and correct any water leaks.

Materials Needed

- $\frac{1}{4}$ " (6 mm) outer diameter flexible copper tubing

NOTE: Add 8' (2 m) to tubing length needed to reach water supply for creation of service loop.

- Brass nut and sleeve (see literature pack)
- Shut-off valve (requires a $\frac{1}{4}$ " or 6 mm hole to be drilled into water supply before valve attachment)
- Adjustable wrench

1 Remove plastic cap (A) from water valve inlet port (B).

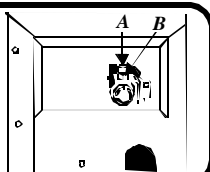

2 Place brass nut and sleeve on copper tube end and insert tube into valve inlet port.

- Attach nut on copper tubing to valve inlet port.

Installing Your Refrigerator

How to Connect the Water Supply *continued*

3 Confirm secure attachment by pulling on tubing.

4 Turn on water supply and correct any leaks.

- Create service loop with remaining tubing and attach to unit with "P" clamp as illustrated. Avoid kinks.

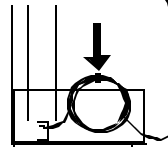

How to Level Your Refrigerator

CAUTION

- To avoid damage to walls and flooring, protect soft vinyl or other flooring with cardboard, rugs, or other protective material.
- To avoid damage or breakage to adjusting bolt, do not use power tools to correct leveling.
- **DO NOT** adjust unit to be any shorter than 68 1/2" inches tall (minus hinge and cap). Doing so may damage underside components.

Materials Needed

- 3/8" hex head driver
- Level

1 Remove toe grille and bottom hinge covers (see previous instructions).

2 Turn both front adjustment screws (A) clockwise to raise and counterclockwise to lower.

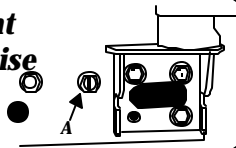

3 Turn both rear adjustment screws (B) clockwise to raise and counterclockwise to lower.

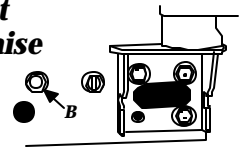

4 Check with level to verify 1/4" tilt to the back for proper door closure.

- If unit is aligned and stable, replace toe grille.

What if my doors are not aligned?

- Locate the higher door, and turn front adjustment screw counterclockwise. Continue until doors are level.
- If bottom of adjustment range is reached, and doors are not level—raise opposite door by turning front adjustment screw clockwise.
- Replace toe grille

What if my unit rocks?

- Turn rear adjustment screw clockwise to raise rocking corner.
- Replace toe grille.

How to Adjust the Temperature Controls

This refrigerator is designed to operate at a household temperature of 55° to 110°F (13° to 43° C).

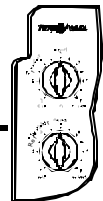

1 Locate refrigerator and freezer controls on upper left wall of fresh food section, and set both controls to 4.

IMPORTANT: Neither section will cool if freezer control is set to Off.

4 Check to see that fresh food section is 38° to 40° F (3° to 4° C).

- Turn control to next highest number if too warm.
- Turn control to next lowest number if too cold.
- Allow 5 to 8 hours for adjustments to take effect.

2 Allow 24 hours for temperatures to stabilize.

IMPORTANT: Due to design of unit, always start temperature adjustments with freezer section.

3 Check to see if freezer temperature is 0° to 2° F (-17° to -16° C).

- Turn control to next highest number if too warm.
- Turn control to next lowest number if too cold.
- Allow 5 to 8 hours for adjustments to take effect.

5 Repeat process, as necessary.

How do I perform a temperature test?

Materials needed

- 2 thermometers measuring -5° to 50°F (-21° to 10°C)
- 2 drinking glasses



For Freezer

- Place thermometer in glass of vegetable oil in middle of freezer and continue with step 3 of *Temperature Adjustment* section.

For Refrigerator

- Place thermometer in glass of water in middle of unit and continue with step 3 of *Temperature Adjustment* section.

About Your Filtration System...

Water Filter Removal and Installation

WARNING

To avoid serious illness or death, do not use unit where water is unsafe or of unknown quality without adequate disinfection before or after use of filter.

CAUTION

- Bypass cartridge DOES NOT filter water. Be sure to have replacement cartridge available when filter change is required.
- If water filtration system has been allowed to freeze, replace filter cartridge.
- If system has not been used for several months, and water has an unpleasant taste or odor, flush system by dispensing 2-3 glasses of water. If unpleasant taste or odor persists, change filter cartridge.

Initial Install of Water Filter

- 1 Remove blue bypass cap and retain for later use.**

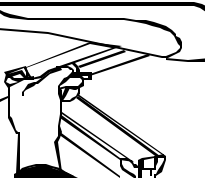

- 2 Remove sealing label from end of filter and insert into filter head.**

- Rotate gently clockwise until filter stops and snap filter cover closed.



- 3 Reduce water spurts by flushing air from system. Run water continuously (approximately 2 minutes) through dispenser until water runs steady.**

- Additional flushing may be required in some households where water is of poor quality.

Replacing Water Filter

IMPORTANT: Air trapped in system may cause water and cartridge to eject. Use caution when removing.

- 1 Turn filter counterclockwise until it releases from filter head.**

- 2 Drain water from filter into sink or toilet, and dispose in normal household garbage.**

- 3 Wipe up excess water in filter cover and continue with installation steps 2 and 3.**

When do I change the water filter?

Select dispenser models feature a water filter change indicator. For instructions on how to operate and reset this feature, refer to the dispenser features section in your manual, or the LCD dispenser booklet for LCD-style dispensers.

For units without indicator feature, filter should be changed approximately every 6 months.

IMPORTANT: Condition of water and amount used determines life span of water filter cartridge. If water use is high, or if water is of poor quality, replacement may need to take place more often.

I'm trying to dispense water to flush the system. Where's the water?

During initial use, allow about a 1 to 2 minute delay in water dispersal to allow internal water tank to fill.

What if I choose not to use the water filtration system?

Dispenser feature may be used without water filter cartridge. If you choose this option, replace filter with blue bypass cap.

How do I order a replacement filter cartridge?

Amana® Replacement Water Filter cartridge model WF 50 is available through Amana® dealers and servicers. You may also order through Amana® Consumer Affairs by using the information on the cover of your manual.



Fresh Food Features

What if These Features are Different from Mine?

This book is intended to show the variety of features that are available in the product line. If your refrigerator does not have all the options that are shown, many of these options may be purchased by contacting the Consumer Affairs Department. See contact information on the cover of your manual.

Interior Shelves

CAUTION

To avoid personal injury or property damage, observe the following:

- Confirm shelf is secure before placing items on shelf.
- Handle tempered glass shelves carefully. Shelves may break suddenly if nicked, scratched, or exposed to sudden temperature change.

Side Glide™ Shelves (some models)

Side Glide™ shelves hook onto a rear double-crossbar assembly. Shelves may be aligned side by side to create a full width level surface, or if attached to separate crossbars, the shelves may slide left or right to accommodate storage needs.

To remove and install shelf:

- To remove shelf, raise shelf 10° to unhook from double crossbar and lift out.
- To install, reverse above procedure.

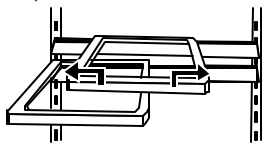

To slide shelves:

- Lift front of shelf slightly and slide left or right.

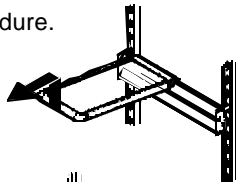

To remove and install double-crossbar assembly:

- To remove, slide assembly up to unhook from metal track.
- To install, reverse above procedure.

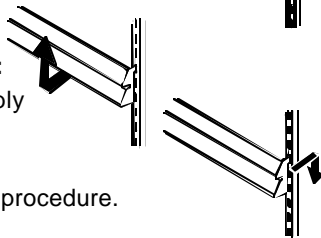

Spillsaver™ Easy Glide™ (some models)

Spillsaver™ Easy Glide™ shelves feature the convenience of easy cleaning with a pull-out design to reach items in the back. For ease of cleaning, glass shelf may be removed by pulling to full extension and lifting out of frame.

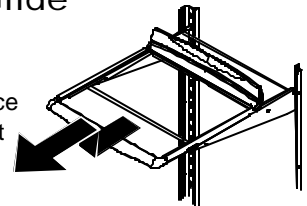

- To remove shelf and frame, see instructions for Spillsaver™ stationary shelves.

Spillsaver™

Spillsaver™ stationary shelves hold simple spills for easier cleaning.

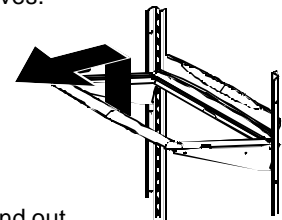

- To remove shelves, lift up and out.
- To install shelves, reverse above procedure.

Rear Shelf Extensions (some models)

Rear shelf extensions help prevent articles from falling off the back of the shelf.

To remove and install shelf extension:

- To remove, pull extension straight up from rear of shelf.
- To install, insert posts of the shelf extension into holes in the shelf frame.

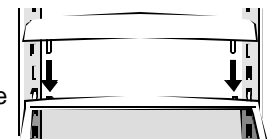

Fresh Food Features

Door Storage

Dairy Center

The dairy center provides convenient storage for items such as butter, yogurt, cheese, etc. This compartment is an adjustable feature located in the door. It can be moved to several different locations to accommodate storage needs.

- To remove, slide dairy center up and pull straight out.
- To install, reverse above procedure.

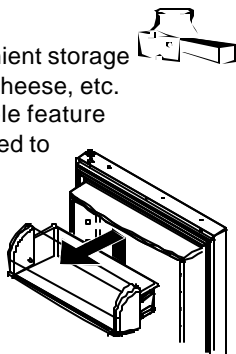

Kid Zone™ (some models)

The Kid Zone™ provides adjustable storage for your child's preferred snacks and beverages.

- To remove, slide Kid Zone™ assembly up and pull straight out.
- To install, reverse above procedure.

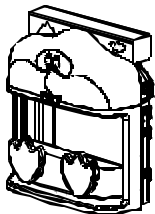

Tilt-Out Door Buckets (some models)

The Tilt-Out Bucket assembly consists of a bucket and frame, providing adjustable, convenient storage for food items in door. The bucket assembly tilts forward for easy access of items, and lifts out for ease in cleaning and adjusting.

To remove and install bucket:

- To remove bucket, tip bucket forward and pull straight out to remove.
- To install bucket, slide bucket into bucket frame and push bucket upright.

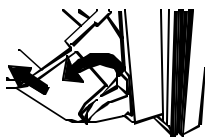

To adjust bucket frame:

- Remove bucket per above instructions.
- Lift frame off door support and place in desired door location.



Beverage Chiller™/ Mini-Chiller™ (some models)

The Temperature-Controlled Beverage Chiller™ and Temperature-Controlled Mini Beverage Chiller™ keep beverages and other items up to 5°F(3°C) colder than the rest of the fresh food section. Air inlet allows air from the freezer section to pass to Beverage Chiller™.

The Beverage Chiller™ control is located on the left wall of fresh food section. Control adjusts amount of air circulating in Beverage Chiller™. Turn control toward the large snowflake icon for colder temperature.



To remove and install Beverage Chiller™:

- If located directly above Chiller, dairy center or door bucket may need to be removed. Refer to appropriate instructions and remove item. Slide Beverage Chiller™ assembly up and pull straight out.
- To install, align one of the Beverage Chiller™ cold air intake holes (A) with one of the two air inlets (B) in door liner. Push assembly down onto door liner retainer until it stops.

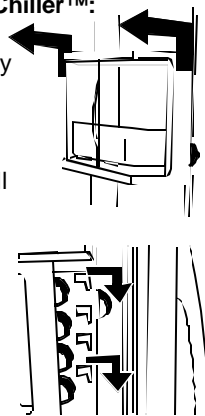

IMPORTANT: Beverage Chiller™ will not operate properly if air intake holes are not aligned with air inlet in door liner.

Door Buckets

Door buckets adjust to meet individual storage needs.

- To remove, slide bucket up and pull straight out.
- To install, reverse above procedure.

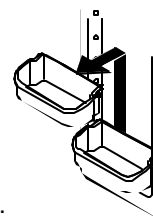

Grip Pads

The Grip Pads prevents objects from sliding in the door bucket. Grip Pads are removable and are top-rack dishwasher safe for easy cleaning.

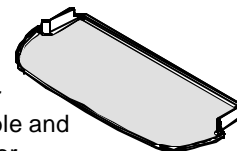

Fresh Food Features

Drawers

Snack Drawer (some models)

This drawer can be used for storage of food items or extra produce. Some models may have climate controls to keep food fresh longer.

Controls (some models)

The climate controls regulate the amount of humidity in the drawer. Use the *low* setting for produce with outer skins. Use the *high* setting for leafy produce.

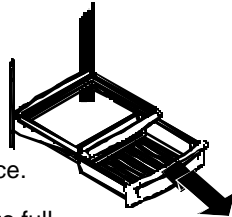

- To remove, pull drawer out to full extension. Tilt up front of drawer and pull straight out.
- To install, reverse above procedure.

Deli/Crisper Drawer *climate controlled*

The Deli/Crisper system provides a drawer with a variable temperature control that keeps the compartment up to 5°F (3°C) colder than refrigerator temperature. This drawer can be used for deli storage or additional produce storage.



NOTE: Cold air directed to the Deli/Crisper System can decrease refrigerator temperature. Refrigerator control may need to be adjusted.

Controls

Located on the wall to the left of the drawer, the climate controls regulate the air temperature in the Deli/Crisper drawer. Set control level to *cold* to provide normal refrigerator temperature for produce with outer skins. Use the *coldest* setting for meats or other deli items.

Crisper Drawer *climate controlled*

Garden Fresh™ crisper keeps produce fresh longer by providing an environment with adjustable humidity.



Controls

The Garden Fresh™ controls regulate the amount of humidity in the crisper drawer. Use the *low* setting for produce with outer skins. Use the *high* setting for leafy produce.

To remove and install drawers:

- To remove drawer, pull drawer out to full extension. Tilt up front of drawer and pull straight out.
- To install, reverse above procedure.



To remove and install crisper shelf:

- Lift off wall supports and remove.
- To install shelf, lower shelf onto wall supports and push in until shelf is flush with rear wall.

Beverage Organizer™ (some models)

The Beverage Organizer™ slides out from underneath the Spillsaver™ Easy Glide™ shelf. The Organizer holds up to twelve 12-ounce beverage cans.

To remove and install Organizer:

- To remove, empty contents of Organizer. Pull Organizer forward to full extension and lift front to release from shelf rail. Pull straight out to remove.
- To install, reverse above procedure.

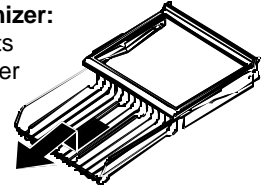

What setting should I use for items in my humidity-controlled drawers?



low

- cauliflower
- corn
- zucchini
- cucumbers
- apples
- oranges
- grapes
- tomatoes



high

- lettuce
- spinach
- celery
- fresh sprouts
- asparagus
- cabbage
- broccoli
- fresh herbs

What setting should I use for items in my temperature-controlled drawer?



cold

- cauliflower
- corn
- zucchini
- cucumbers
- apples
- oranges
- grapes
- tomatoes



coldest

- steaks
- bacon
- cold cuts
- hot dogs
- hard cheeses
- bacon

It is not recommended that lettuce, or other leafy produce, be stored in this drawer.

What can I do to prolong the life of my produce?

Please observe the following rules when storing produce in humidity-controlled drawers:

- DO NOT wash produce before placing in crispers. Any additional moisture added to the drawers may cause produce to prematurely spoil.
- DO NOT line crispers with paper towels. Towels will retain moisture.
- Follow control instructions carefully. Not setting controls correctly may damage produce.

Freezer Features

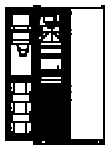

What if These Features are Different from Mine?

This book is intended to show the variety of features that are available in the product line. If your refrigerator does not have all the options that are shown, many of these options may be purchased by contacting the Consumer Affairs Department. See contact information on the cover of your manual.

Primary Features



CAUTION

To avoid property damage, observe the following:

- Do not force ice maker arm down or up.
- Do not place or store anything in ice storage bin.



WARNING

To avoid possible injury, including death, do not place glass items in Quick Chill Zone™. Glass objects may shatter or explode if exposed to extreme cold.

Automatic Dispensing Ice Maker

This ice maker creates the ice used in the dispensing system.

Using Ice Maker for the First Time

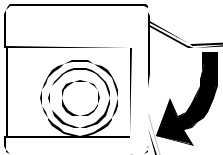
- Confirm ice bin is in place and ice maker arm is down. 
- After freezer section reaches between 0° to 2°F (-18° to -17° C), ice maker fills with water and begins operating.
- Allow approximately 24 hours after installation to receive first harvest of ice.
- Discard ice created within first 12 hours of operation to verify system is flushed of impurities.

Operating Instructions

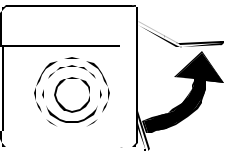
- Confirm ice bin is in place and ice maker arm is down.
- After freezer section reaches 0° to 2°F (-18° to -17° C), ice maker fills with water and begins operating. You will have a complete harvest of ice approximately every 3 hours. 
- Stop ice production by raising ice maker arm until click is heard.
- Ice maker will remain in the off position until arm is pushed down.

Quick Chill Zone™

Quick Chill Zone™ provides a space for items to be chilled or frozen quickly.

- To remove, lift Quick Chill Zone™ from ice bin rails and pull straight out.
- To install, reverse above procedure.

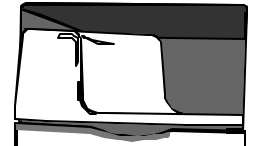

Ice Storage Bin

The ice storage bin is located below the automatic dispensing ice maker.

To remove and install ice storage bin:

- To remove bin, remove Quick Chill Zone™. Raise ice maker arm to deactivate ice maker. 
- Lift front of bin and pull out to its full extension. Lift up front of bin and remove.
- To install, slide bin into rails below ice maker until bin locks into place. Drop ice maker arm to activate ice maker, and replace Quick Chill Zone™.

IMPORTANT: Ice bin must be locked in proper place for proper ice dispensing. If freezer door does not close, bin is not in proper location. Turn auger driver as shown to properly align ice bin with back of unit.

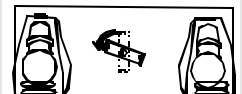

Freezer Features

Shelves

Stor-Mor® System

Baskets slide out for easy access of items in back. Shelves can be removed to meet individual storage needs.

To remove and install Stor-Mor® shelf:

- To remove, snap right side of shelf from cabinet railing and remove from wall mounting clips.
- To install, reverse above procedure.

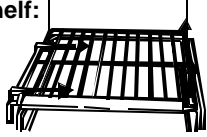

NOTE: Back of shelf must be flush with back of cabinet to secure firmly in cabinet railing. Improper alignment will cause shelf to slide.

To remove and install baskets:

- To remove, pull basket forward to full extension. Lift front handle to release basket from rails and remove.
- To install, reverse above procedure.

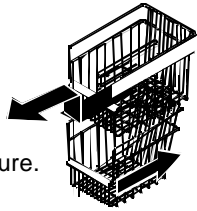

Fixed Freezer Shelf

To remove and install shelves:

- Remove shelf from wall mounting clips and pull out of left side mounting holes.
- To install, reverse above procedure.

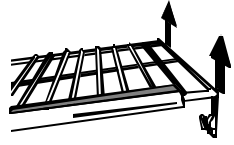

Hanging Wire Shelf (some models)

Hanging wire shelf provides extra storage for ice cube trays, boxed frozen foods, ice packs, etc.

To remove shelf:

- Pinch rung hook of hanging wire shelf inward to release hanging wire shelf from right side of Stor-Mor® shelf. Shelf will swing downward.
- Press rung hook of hanging wire shelf outward to remove shelf from freezer section.

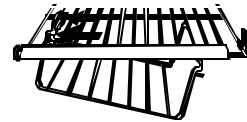

To install shelf:

- Perform above steps in reverse order.

Door Storage

Door Buckets

- Refer to Fresh Food section for instructions.

Tilt-Out Door Buckets (some models)

- Refer to Fresh Food section for instructions.

Dispenser Features

Primary Features

Dispenser Light *not shown*

A light activates within the dispenser area at full power when dispensing ice or water.

Front Fill Button (some models)

The Front Fill button works independently of the dispenser controls, providing an up-front alternative to the dispenser pad for dispensing water. This feature is convenient for filling large items that will not fit into the dispenser area (i.e. sport bottles, pitchers, large pans, coffee pots).

This feature allows added convenience of dispensing ice and water simultaneously.

To use, choose your preferred ice mode from dispenser control panel. Press container against dispenser pad while pressing the Front Fill button.

Dispenser Pad

The dispenser pad is located on the back wall of the dispensing area. When the dispenser pad is pressed, the selection chosen on your dispenser control panel will dispense.

Removable Tray

The removable tray at the bottom of the dispenser area is designed to collect small spills and may be easily removed for cleaning and emptying purposes.

IMPORTANT: Removable tray does not drain. Continuous water running into tray will cause tray to overflow.

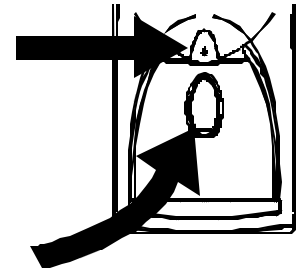

Water Dispenser Operation

CAUTION

To avoid personal injury or property damage, observe following instructions:

- Do not put fingers, hands, or any foreign object into dispenser opening.
- Do not use sharp objects to break ice.
- Do not dispense ice directly into thin glass, fine china, or delicate crystal.

NOTE: During initial use of water dispenser, allow an approximate 1-2 minute delay in water dispersal to allow internal water tank to fill. Discard first 10-14 containers of water after initially connecting refrigerator to household water supply and extended periods of nonuse.

To use dispenser pad:

- Choose water selection from dispenser control panel.
- Press sturdy, wide-mouthed container against dispenser pad.
- Release pressure on dispenser pad to stop water from dispensing. A small amount of water may continue to dispense, and collect in dispenser tray. Large spills should be wiped dry.

To use Front Fill button (some models):

- Align container under Front Fill button using blue water droplet as guide.
- Press and hold Front Fill button.
- Release button when desired fill is reached. A small amount of water may continue to dispense, and collect in dispenser tray. Large spills should be wiped dry.

NOTE: If water dispenser is active for more than 3 minutes, an automatic lock out sensor will shut down power to dispenser area. See **Automatic Lock Out** for further information.

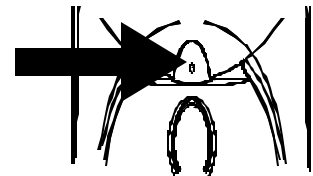
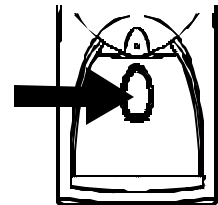

Dispenser Features

Control Features

NOTE: These directions pertain to 5-button and 3-button controls only. If your unit has LCD controls, please refer to the information booklet located in your literature packet.

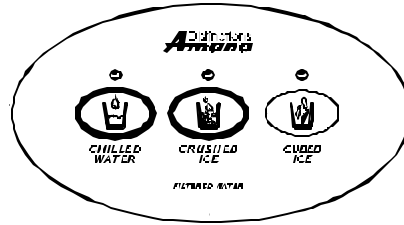
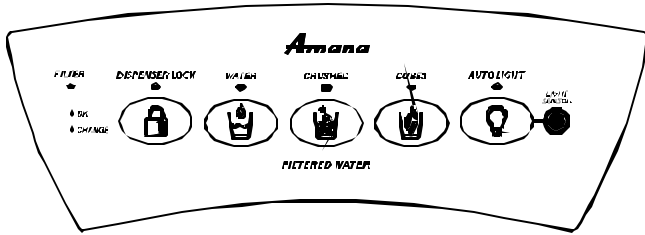

Ice Dispenser Operation

To dispense ice:

- Select *Cubed* or *Crushed* ice mode by pushing button on dispenser control panel. A green indicator light above button shows mode selection.
- Press container against dispenser pad. When dispensing crushed ice, hold container as close to chute as possible to reduce spraying. **Selection mode may not be changed while ice dispenser is in operation.**

NOTE: If dispenser is active for more than 3 minutes, an automatic lock out sensor will shut down power to dispenser area. See **Automatic Lock Out** for further information.

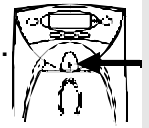

Dispenser Lock (some models)

This feature prevents ice or water from being dispensed.



To lock and unlock dispenser:

- To lock dispenser, press and hold *Dispenser Lock* button for 3 seconds. A green indicator light above button confirms dispenser is locked.
- To unlock dispenser, hold *Dispenser Lock* button for 3 seconds. Green indicator light above button will go out.

What is the Automatic Lock Out feature?

The Automatic Lock Out feature shuts down power to the water and ice dispenser when either dispenser has run continuously for approximately 3 minutes. If this mode goes into effect, the green light will activate above the *Dispenser Lock* button.

To unlock dispenser:

- To unlock dispenser, hold *Dispenser Lock* button for 3 seconds. Green indicator light above button will go out.

Filter Status Indicator Light (some models)

The Filter Status Indicator Light serves as a reminder to replace the water filter. A green light indicates that the filter is in good condition. A red light indicates the filter should be changed. Once light turns red, it will remain red until function is reset.



To reset indicator:

- Press and hold both *Dispenser Lock* and *Water* buttons simultaneously for 4 seconds. The green Filter Status Indicator Light will flash 3 times when the function has successfully reset.

Auto Light (some models)

The *Auto Light* function offers the ability to activate the dispenser light at half-power when the *Light Sensor* detects that the light levels in room are low.

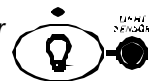

To activate and deactivate *Auto Light*:

- To activate, press *Auto Light* button located on control panel. A green indicator light above button displays to show that sensor is active.
- To deactivate, press *Auto Light* button. Green indicator light will go out.

NOTE: Dispenser light will operate whether or not *Auto Light* is selected.

Sabbath Mode

This mode is intended to deactivate power to the LED and dispenser lights, while allowing the controls to remain operational.

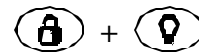

To activate Sabbath Mode:

- Press and hold both *Dispenser Lock* and *Auto Light* buttons simultaneously for 3 to 4 seconds. After 3 to 4 seconds, the LED and dispenser lights will turn off. **Dispenser light will not activate during dispensing while in this mode.**

NOTE: In the event that power is interrupted while the Sabbath Mode is active, the control will remain in Sabbath Mode when power returns.

To deactivate Sabbath Mode:

- Press and hold both *Dispenser Lock* and *Auto Light* buttons simultaneously for 3 to 4 seconds. After 3 to 4 seconds, the LED and dispenser lights will activate.

Hints and Care

What cleaners does Amana recommend for my stainless steel product?

Amana has a cleaner available for purchase (Part # 31960801) through our Consumer Affairs division.

For this, or a list of other recommended cleaning products, please contact us at Amana Consumer Affairs using the information on the cover of your Owner's Manual.

How do I remove an odor from my refrigerator?

1. Remove all food.
2. Disconnect refrigerator.
3. Clean the following items using the appropriate instructions in *How to Clean Your Unit* :
 - Walls, floor, and ceiling of cabinet interior.
 - Drawers, shelves, and gaskets according to the instructions in this section.
4. Pay special attention to clean all crevices by completing the following steps:
 - Dilute mild detergent and brush solution into crevices using a plastic bristle brush.
 - Let stand for 5 minutes.
 - Rinse surfaces with warm water. Dry surfaces with a soft, clean cloth.
5. Wash and dry all bottles, containers, and jars. Discard spoiled or expired items.
6. Wrap or store odor-causing foods in tightly-sealed containers to prevent reoccurring odors.
7. Connect power to refrigerator and return food to unit.
8. After 24 hours, check if odor has been eliminated.

If odor is still present...

1. Remove drawers and place on top shelf of refrigerator.
2. Pack refrigerator and freezer sections—including doors—with crumpled sheets of black and white newspaper.
3. Place charcoal briquettes randomly on crumpled newspaper in both freezer and refrigerator compartments.
4. Close doors and let stand 24–48 hours.
5. Repeat steps 5 through 7.

If odor was not eliminated, contact Consumer Affairs Department using the information in the front of your Owner's Manual.

How to Clean Your Unit



WARNING

To avoid electrical shock which can cause severe personal injury or death, disconnect power to refrigerator before cleaning. After cleaning, connect power.

CAUTION

To avoid personal injury or property damage:

- Read and follow manufacturer's directions for all cleaning products.
- Do not place buckets, shelves, or accessories in dishwasher. Cracking or warping of accessories may result

AREA	DO NOT USE	DO...
Textured Doors and Exterior Cabinet Interior	<ul style="list-style-type: none"> • Abrasive or harsh cleaners • Ammonia • Chlorine bleach • Concentrated detergents or solvents • Metal or plastic-textured scouring pads 	<ul style="list-style-type: none"> • Use 4 tablespoons (60 milliliters) of baking soda dissolved in 1 quart (1 liter) warm soapy water. • Rinse surfaces with clean warm water and dry immediately to avoid water spots
Stainless Steel Doors and Exterior IMPORTANT: <i>Damage to stainless steel finish due to improper use of cleaning products or non-recommended products is not covered under any warranty</i>	<ul style="list-style-type: none"> • Abrasive or harsh cleaners • Ammonia • Chlorine bleach • Concentrated detergents or solvents • Metal or plastic-textured scouring pads • Vinegar-based product • Citrus-based cleaners 	<ul style="list-style-type: none"> • Use warm, soapy water and a soft, clean cloth or sponge. • Rinse surfaces with clean warm water and dry immediately to avoid water spots
Dispenser Controls	<ul style="list-style-type: none"> • Abrasive or harsh cleaners • Ammonia • Chlorine bleach • Concentrated detergents or solvents • Metal or plastic-textured scouring pads 	
Door Gaskets	<ul style="list-style-type: none"> • Abrasive or harsh cleaners • Metal or plastic-textured scouring pads 	
Condenser Coil <i>Remove toe grille to access</i>	N/A	<ul style="list-style-type: none"> • Use a vacuum cleaner hose nozzle
Condenser Fan Outlet Grille <i>See back of refrigerator</i>		<ul style="list-style-type: none"> • Use a vacuum cleaner hose nozzle with brush attachment.
Accessories <i>Shelves, buckets, drawers, etc</i>	<ul style="list-style-type: none"> • A Dishwasher 	<ul style="list-style-type: none"> • Follow removal and installation instructions from appropriate feature section. • Allow items to adjust to room temperature. • Dilute mild detergent and use a soft clean cloth or sponge for cleaning. • Use a plastic bristle brush to get into crevices • Rinse surfaces with clean warm water. • Dry glass and clear items immediately to avoid spots.

Hints and Care

How to Remove and Replace Light Bulbs



WARNING

To avoid electrical shock which can cause severe personal injury or death, disconnect power to refrigerator before replacing light bulb. After replacing light bulb, connect power.



CAUTION

To avoid personal injury or property damage, observe the following:

- Allow light bulb to cool.
- Wear gloves when replacing light bulb.

Upper fresh food section

1. Locate finger gaps on each side of clear light shield. Insert fingers and press in on each side of shield. Pull shield down and remove.
2. Remove light bulbs.
3. Replace with appliance bulbs **no greater than 40 watts**.
4. Replace light bulb cover by inserting front tabs of light shield into holes in liner directly in front of light assembly.



Lower fresh food section and Non-dispensing model freezer section

1. Pinch bottom tabs (**A**) on light cover and pull straight out.
2. Remove light bulb.
3. Replace bulb with appliance bulb **no greater than 40 watts**.
4. Insert top tabs (**B**) of light cover into refrigerator liner and snap bottom portion over light assembly.

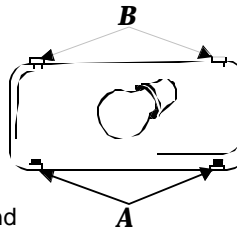

Dispensing model freezer section

1. Remove ice bin by lifting front of bin and pulling out.
2. Remove light bulb cover by pinching top tab (**A**) and pulling cover out of liner.
3. Remove light bulb. Replace with appliance bulb **no greater than 40 watts**.
4. Insert bottom tab (**B**) of light cover into liner and snap top portion over light assembly.
5. Replace ice bin by sliding in until bin locks into place.

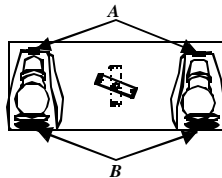

Ice 'N Water dispenser

1. Locate light bulb inside top edge of dispenser frame. Unscrew to remove.
2. Replace light bulb with a 6-watt, 120 volt bulb.



How to Get the Most Out of Your Energy Dollar

- When placing refrigerator into final position, allow for 1" clearance around the top and sides of unit to supply ample ventilation for optimum energy efficiency.
- Avoid overcrowding refrigerator shelves. This reduces effectivity of air circulation around food and causes refrigerator to run longer.
- Avoid adding too much warm food to unit at one time. This overloads compartments and slows rate of cooling.
- Do not use aluminum foil, wax paper, or paper toweling as shelf liners. This decreases air flow and causes unit to run less efficiently.
- A freezer that is $\frac{2}{3}$ full runs most efficiently.
- Locate refrigerator in coolest part of room. Avoid areas of direct sunlight, or near heating ducts, registers, or other heat producing appliances. If this is not possible, isolate exterior by using a section of cabinet or an added layer of insulation.
- Refer to owner's manual section on temperature controls for recommended control settings
- Clean door gaskets every three months according to Owner's Manual cleaning instructions. This will assure that door seals properly and unit runs efficiently.
- Take time to organize items in refrigerator to reduce time that door is open.
- Be sure your doors are closing securely by leveling unit as instructed in your Owner's Manual.
- Clean condenser coils of as indicated in the owner's manual every 3 months. This will increase energy efficiency and cooling performance.

Trouble Shooting

NOISE

Today's refrigerators have new features and are more energy efficient. Foam insulation is very energy efficient and has excellent insulating capabilities, however, foam insulation is not as sound absorbent. As a result, certain sounds may be unfamiliar. In time, these sounds will become familiar. Please refer to this information before calling service.

TOPIC	POSSIBLE CAUSE	SOLUTION
Clicking	Freezer control (A) clicks when starting or stopping compressor.	Normal operation
	Defrost timer (B) sounds like an electric clock and snaps in and out of defrost cycle.	Normal operation
Air rushing or whirring	Freezer fan (C) and condenser fan (D) make this noise while operating.	Normal operation
Gurgling or boiling sound	Evaporator (E) and heat exchanger (F) refrigerant makes this noise when flowing.	Normal operation
Thumping	Ice cubes from ice maker (some models) drop into ice bucket (G) .	Normal operation
	Dispenser ice chute (H) closing.	Normal operation
Vibrating noise	Compressor (I) makes a pulsating sound while running.	Normal operation
	Refrigerator is not level.	See <i>Installation Instructions</i> for details on how to level your unit.
Buzzing	Ice maker water valve (J) hookup (some models) buzzes when ice maker fills with water.	Normal operation
Humming	Ice maker (K) is in the 'on' position without water connection.	Stop sound by raising ice maker arm to 'off' position. See <i>Automatic Ice Maker</i> section in your owner's manual for details.
	Ice auger (L) (some models) hums as auger agitates ice during dispensing.	Normal operation
	Compressor (I) can make a high pitched hum while operating.	Normal operation
	Solenoid valve (M) operating ice chute door.	Normal operation

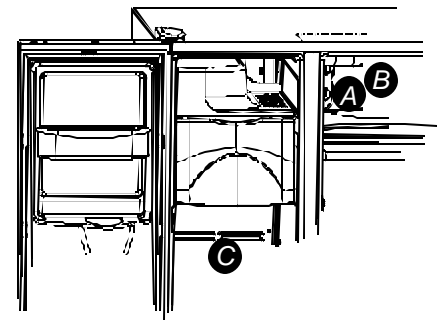
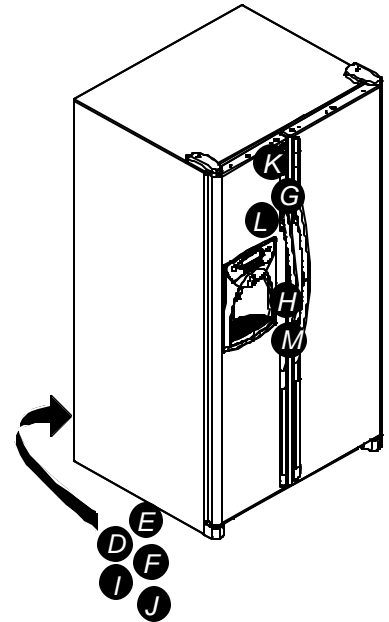

OPERATION

Freezer control and lights are on, but compressors are not operating.	Refrigerator is in defrost mode.	Normal operation Wait 40 minutes to see if refrigerator restarts.
Deli/Crisper system temperature is too warm	Control settings are too low.	See section on Deli/Crisper system to adjust controls.
	Freezer controls are set too low.	See controls section in owner's manual on how to adjust your controls.
	Drawer is improperly positioned.	See section on Deli/Crisper system to verify drawer positioning.
Refrigerator does not operate	Refrigerator is not plugged in.	Plug in unit.
	Freezer control is not on.	See section on controls in your owner's manual.
	Fuse is blown, or circuit breaker needs to be reset.	Replace any blown fuses. Check circuit breaker and reset if necessary.
	Power outage has occurred	Call local power company listing to report outage.
Refrigerator still won't operate	Unit is malfunctioning.	Unplug refrigerator and transfer food to another unit. If another unit is not available, place dry ice in freezer section to preserve food. Warranty does not cover food loss . Contact service for assistance.
Food temperature is too cold	Condenser coils are dirty.	Clean according to cleaning instructions in your owner's manual.
	Refrigerator or freezer controls are set too high.	See controls section in owner's manual on how to adjust your controls.
	Beverage Chiller™ (some models) is improperly positioned.	See section on Temperature-Controlled Beverage Chiller™ to verify proper positioning.

Trouble Shooting

OPERATION

TOPIC	POSSIBLE CAUSE	SOLUTION
Food temperature appears too warm	Door is not closing properly.	Refrigerator is not level. See <i>Installation Instructions</i> for details on how to level your unit. Check gaskets for proper seal. Clean, if necessary, according to cleaning instructions in owner's manual. Check for internal obstructions that are keeping door from closing properly (i.e. improperly closed drawers, ice buckets, oversized or improperly stored containers or foodstuffs, etc.).
	Controls need to be adjusted.	See the controls section in your owner's manual for assistance in how to adjust your controls.
	Condenser coils are dirty.	Clean according to cleaning instructions in your owner's manual.
	Rear air grille is blocked.	Check the positioning of food items in refrigerator to make sure grille is not blocked. Rear air grille is located behind crisper drawers.
	Door has been opened frequently, or has been opened for long periods of time.	Reduce time door is open. Organize food items efficiently to assure door is open for as short a time as possible. Allow interior environment to adjust for period the door has been open.
	Food has recently been added.	Allow time for recently-added food to reach refrigerator or freezer temperature.
	Refrigerator has an odor	Compartment is dirty or has odor-causing food.
Air filter (some models) needs to be changed.		Change air filter.
Water droplets form on outside of refrigerator	Check gaskets for proper seal.	Clean, if necessary, according to cleaning instructions in owner's manual.
	Humidity levels are high.	Normal during times of high humidity.
	Controls require adjustment	See the controls section in your owner's manual for assistance in how to adjust your controls.
Water droplets form on inside of refrigerator	Humidity levels are high or door has been opened frequently.	See the controls section in your owner's manual for assistance in how to adjust your controls.
	Check gaskets for proper seal.	Reduce time door is open. Organize food items efficiently to assure door is open for as short a time as possible. Clean, if necessary, according to cleaning instructions in owner's manual.
Refrigerator or ice maker make unfamiliar sounds or seems too loud	Normal operation	Refer to noise section of troubleshooting guide in owner's manual.
Deli/Crisper System and/or crisper drawers do not close freely	Contents of drawer, or positioning of items in the surrounding compartment could be obstructing drawer	Reposition food items and containers to avoid interference with the drawers.
	Drawer is not in proper position	See section on Deli/Crisper System and/or crisper drawer section for proper placement.
	Refrigerator is not level.	See <i>Installation Instructions</i> for details on how to level your unit.
	Drawer channels are dirty or need treatment.	Clean drawer channels with warm, soapy water. Rinse and dry thoroughly. Apply a thin layer of petroleum jelly to drawer channels.
Refrigerator runs too frequently	Doors have been opened frequently or have been opened for long periods of time.	Reduce time door is open. Organize food items efficiently to assure door is open for as short a time as possible. Allow interior environment to adjust for period the door has been open.
	Humidity or heat in surrounding area is high.	Normal operation
	Food has recently been added.	Allow time for recently-added food to reach refrigerator or freezer temperature.
	Unit is exposed to heat by environment or by appliances nearby.	Evaluate your unit's environment. Unit may need to be moved to run more efficiently.
	Condenser coils are dirty.	Clean according to cleaning instructions in your owner's manual.

Trouble Shooting

OPERATION  (continued)

TOPIC	POSSIBLE CAUSE	SOLUTION
Refrigerator runs too frequently (continued)	Controls need to be adjusted.	See the controls section in your owner's manual for assistance in how to adjust your controls.
	Door is not closing properly	Refrigerator is not level. See <i>Installation Instructions</i> for details on how to level your unit
		Check for internal obstructions that are keeping door from closing properly (i.e. improperly closed drawers, ice buckets, oversized or improperly stored containers or foodstuffs, etc.).
	Check gaskets for proper seal. Clean, if necessary, according to cleaning instructions in owner's manual.	

ICE & WATER

Water appears cloudy	Air or air bubbles in water.	This is normal when first using dispenser and will disappear with use.
Particles in water and/or ice cubes.	Carbon dust from water filter cartridge.	Initial water ejected through cartridge may contain harmless carbon dust flushed from cartridge. Particles are safe for consumption. Will disappear after the first few uses.
	Concentrations of minerals in water will form particles when water becomes frozen and melts.	Particles are not harmful and naturally occur in water supplies.
No indicator lights are lit on dispenser control (some models)	Freezer door is not closed.	Verify that freezer door is closed. Power is removed from the control when freezer door is opened.
	Refrigerator is not plugged in.	Plug in unit.
	Fuse is blown, or circuit breaker needs to be reset.	Replace any blown fuses. Check circuit breakers for any tripped circuits.
	Power outage has occurred.	Call local power company listing to report outage.
	Refrigerator is in Sabbath Mode.	See dispenser control instructions for further information.
Neither ice nor water is dispensed when pads are pushed (some models)	Freezer door is not closed.	Verify that freezer door is closed. Power is removed from the control when freezer door is opened.
	Controls are in lock mode.	See dispenser control instructions for further information.
	Water tank is filling.	At initial use, there is an approximate 45-second delay in dispensing while the internal water tank is filling.
	Ice maker or ice maker-equipped unit has just recently been installed or a large amount of ice has just been used.	Wait 24 hours for ice production to begin and for ice maker to restock after emptied.
Ice maker is not producing enough ice or ice is malformed (some models)	Water filter is clogged or needs to be changed.	Change water filter.
	Ice maker has just recently been installed or a large amount of ice has just been used.	Wait 24 hours for ice production to begin and for ice maker to restock after emptied.
	Water pressure is too low.	Low water pressure can cause valve to leak. Water pressure must be between 20 to 100 pounds per square inch to function properly. A minimum pressure of 35 pounds per square inch is recommended for units with water filters.
Ice maker is not producing ice (some models)	Water filter is clogged or needs to be changed.	Change water filter.
	Ice maker arm is not in correct position	Confirm ice maker arm is down. See <i>Automatic Ice Maker</i> section in your owner's manual for details.
	Household water supply is not reaching water valve	Check water connection procedure in your <i>Installation Instructions</i> .
	Copper or plastic tubing has kinks.	Turn off water supply and remove kinks. If kinks cannot be removed, replace tubing.
	Water pressure is too low.	Water pressure must be between 20 to 100 pounds per square inch to function properly. A minimum pressure of 35 pounds per square inch is recommended for units with water filters.
	Check freezer temperature.	See the controls section in your owner's manual for assistance on how to adjust your controls. Freezer must be between 0 to 2°F (-18 to -17°C) to produce ice.
	Ice bin is not installed properly	See ice bin section for proper installation and alignment.

Trouble Shooting

ICE & WATER



TOPIC	POSSIBLE CAUSE	SOLUTION
Ice maker is not producing ice (some models-continued)	Improper water valve was installed.	Check water connection procedure in your <i>Installation Instructions</i> . Self-piercing and $\frac{3}{16}$ " saddle valves cause low water pressure and may clog the line over time. Amana is not responsible for property damage due to improper installation or water connection.
Unit is leaking water	Plastic tubing was used to complete water connection.	Amana recommends using copper tubing for installation. Plastic is less durable and can cause leakage. Amana is not responsible for property damage due to improper installation or water connection.
	Improper water valve was installed.	Check water connection procedure in your <i>Installation Instructions</i> . Self-piercing and $\frac{3}{16}$ " saddle valves cause low water pressure and may clog the line over time. Amana is not responsible for property damage due to improper installation or water connection.
Ice forms in inlet tube to ice maker	Water pressure is low.	Water pressure must be between 20 to 100 pounds per square inch to function properly. A minimum pressure of 35 pounds per square inch is recommended for units with water filters.
	Freezer temperature is too high.	See the controls section in your owner's manual for assistance on how to adjust your controls. Freezer is recommended to be between 0 to 2°F (-18 to -17°C).
Water flow is slower than normal	Water pressure is low.	Water pressure must be between 20 to 100 pounds per square inch to function properly. A minimum pressure of 35 pounds per square inch is recommended for units with water filters.
	Improper water valve was installed.	Check water connection procedure in your <i>Installation Instructions</i> . Self-piercing and $\frac{3}{16}$ " saddle valves cause low water pressure and may clog the line over time. Amana is not responsible for property damage due to improper installation or water connection.
	Copper or plastic tubing has kinks.	Turn off water supply and remove kinks. If kinks cannot be removed, replace tubing.
	Water filter is clogged or needs to be changed.	Change water filter.
Dispenser water is not cold	Refrigerator has been recently installed	Allow approximately 12 hours for water in holding tank to chill.
	Water supply in holding tank has been depleted.	
	Water has settle into water lines outside holding tank and has warmed to room temperature.	Discard first glass of water and refill.

Water Filter Data



System Specification and Performance Data Sheet
Refrigerator Water Filter Cartridge Model WF50

Specifications

Service Flow Rate (Maximum)	0.75 GPM (2.83 L/min)
Rated Service Life WF50-NI300 (Maximum)	300 gallons/ 1135 liters
Rated Service Life WF50-WI500 (Maximum)	500 gallons/ 1892 liters
Maximum Operating Temperature	100° F/38° C
Minimum Pressure Requirement	35 psi/ 138 kPa
Maximum Operating Pressure	120 psi/ 827 kPa

General Use Conditions: Read this Performance Data Sheet and compare the capabilities of this unit with your actual water treatment needs.

DO NOT use this product where water is microbiologically unsafe or of unknown quality without adequate disinfection before or after the system. System certified for cyst reduction may be used on disinfected water that may contain filterable cysts.

The Amana® Clean 'n Clear™ retractable water filtration system uses a WF50 replacement cartridge (see Amana® contact information at the front of your manual to order). Timely replacement of filter cartridge is essential for performance satisfaction from this filtration system. Please refer to the applicable section in this owner's manual for general operation, maintenance requirements and troubleshooting.

This systems has been tested according to ANSI/NSF 42 and 53 for reduction of the substances listed below. The concentration of the indicated substances in water entering the system was reduced to a concentration less than or equal to the permissible limit for water leaving the system, as specified in ANSI/NSF 42 and 53.

Performance Data*

Substance	Influent Water	Effluent Average	Average % Reduction	Maximum Effluent	Min. Required Reduction	Inlet pH
Lead	0.15 mg/L	0.001 mg/L	99.33%	0.001 mg/L	0.010 mg/L	6.5
Lead	0.15 mg/L	0.002 mg/L	98.66%	0.003 mg/L	0.010 mg/L	8.5
Cyst	25000 count/mL	1count/mL	99.99%	3 count/mL	> 99.95%	NA
Turbidity	11.8 NTU	0.12 NTU	98.98%	0.18 NTU	0.5 NTU	NA
Lindane	0.00063 mg/L	0.00005 mg/L	92.06%	0.00005 mg/L	0.00001 mg/L	NA
Atrazine	0.0097 mg/L	0.0002 mg/L	97.93%	0.0006 mg/L	0.003 mg/L	NA
Chlorine	1.9 mg/L	0.09 mg/L	95.26%	0.17 mg/L	≥75%	NA
Particulate**	286667 count/mL	900 count/mL	99.68%	2400 count/mL	≥85%	NA
2,4-D	291.6667 ug/L	45.45 ug/L	84.42%	100 ug/L	0.0017 mg/L	NA
Asbestos	458 MFL/mL	0.16 MFL/mL	99.96%	0.16 MFL/mL	99%	NA

* Tested using a flow rate of 0.75 GPM (2.83 L/min.) and a maximum pressure of 120 psi (827 kPa) under standard laboratory conditions, however, actual performance may vary. Health Claim Performance tested and certified by NSF International

** Particle size range classification of test. Particles used were 0.5 –1 microns.



California Certificate number 01-1486

Amana Refrigerator Warranty

First Year

Amana will replace, free of charge, any part which is defective due to workmanship or materials.

Second through Fifth Year

Amana will replace free of charge, any sealed system component (compressor, condenser, evaporator, drier and interconnecting tubing) and repair any food compartment liner (exclusive of door liner) which is defective due to workmanship or materials.

Warranty Limitations

- Begins at date of original purchase.
- Excludes original and replacement water or air filter cartridges (if equipped with the filtration system). Original and replacement cartridges are warranted for 30 days, parts only, against defects of material or workmanship.
- Service must be performed by an authorized Amana technician.
- Damage due to shipping and handling is not covered by this warranty.

Warranty Is Void If

Repairs resulting from the following:

- Serial plate is defaced.
- Product is used on a commercial, rental, or leased basis.
- Product has defect or damage due to product accident, alteration, connection to an improper electrical supply, fire, flood, lightning, or other conditions beyond the control of Amana.
- Product is improperly installed or used.

Owner's Responsibility

- Provide proof of purchase (sales receipt).
- Provide normal care and maintenance. Replace owner replaceable items where directions appear in Owner's Manual.
- Make product reasonably accessible for service.
- Pay premium service costs for service outside technician's normal business hours.
- Pay for service calls related to product installation and usage.

Amana Appliances Factory Service

1-800-628-5782 inside USA

For more information,

Amana Appliances Consumer Services

Amana Appliances

2800 220th Trail

Amana, Iowa 52204

1-800-843-0304 inside USA

(319) 622-5511 worldwide

www.amana.com

IN NO EVENT SHALL AMANA BE LIABLE FOR INCIDENTAL OR CONSEQUENTIAL DAMAGES.

This warranty gives you specific legal rights, and you may have others which vary from state to state. For example, some states do not allow the exclusion or limitation of incidental or consequential damages, so this exclusion may not apply to you.

